

Kolibri

- Kolibri applications 19
- Kolibri dimensions 20
- Kolibri types 21
- Kolibri sizes 22
- Kolibri height 10 23
- Kolibri height 15 24
- Kolibri height 22 26
- Kolibri height 30 28
- Kolibri height 40 33
- Kolibri height 50 35
- Kolibri height 65 37
- Kolibri parts 39
- Kolibri assembly 40
- Kolibri flange connect. 42
- Kolibri part numbers 44



closed + open

The inexpensive energy chain for light-weight applications. The patented opening offers high rigid torsion behaviour and comfortable handling in one.

- easy access by flap stays
- extremely rigid and wear resistant
- unique separation with the pinch stay
- smallest dimensions

All ekd plastic energy chains are equipped with integrated connectors. Additional mounting parts are not needed.

Dimensions

bending radii:	15	to	400 mm
inner height:	7	to	50 mm
inner width:	7	to	195 mm
weight:	0.06	to	2.7 kg/m

Travel distance

The maximum travel distance is given by the arrangement and the load (weight of the lines). At normal arrangements the maximum travel distance is double the free carrying length. Support rollers or similar equipment may exceed this value.

In gliding arrangements travel distances up to 100 m are possible (according to the application).

For longer travels see chapter on design guidelines.

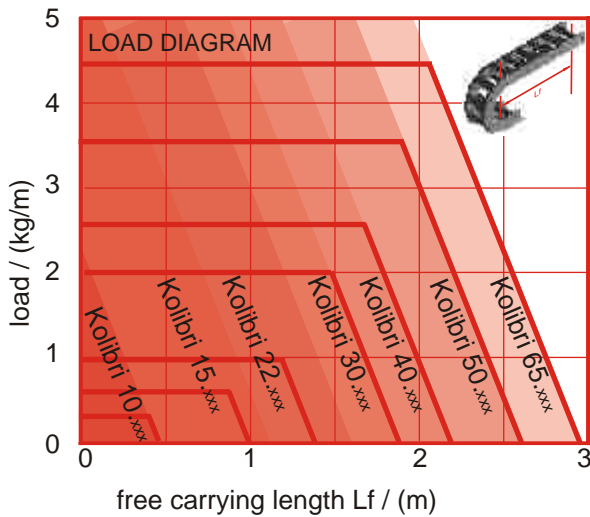

Travel speed

There are no limits for the travel speed in general. But with gliding arrangements application specific influences have to be taken into account.

Acceleration

There are no limits for the accelerations, in general. Limits may occur through the tensile stresses at high line weights.

Temperature

Long term temperature limits are between -20°C and 100°C.

Special variants

- | | |
|--------|------------------------|
| ELTOLA | ... silent running |
| ATEX | ... EX-protection |
| ESD | ... antistatic |
| V-0 | ... self extinguishing |

APPLICATION AREAS

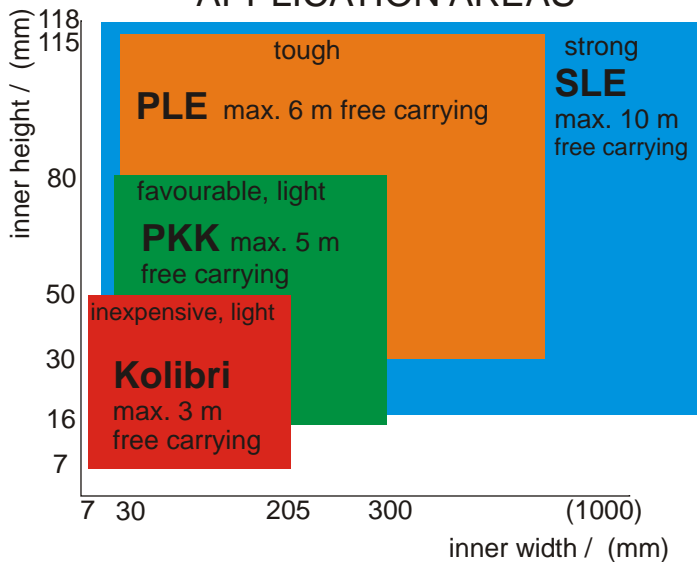

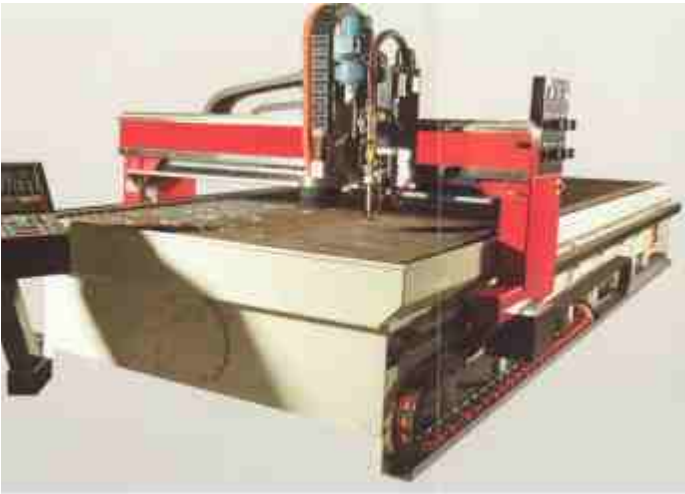

robotics, handling,
transportation, paper production,
textile industries, water plants



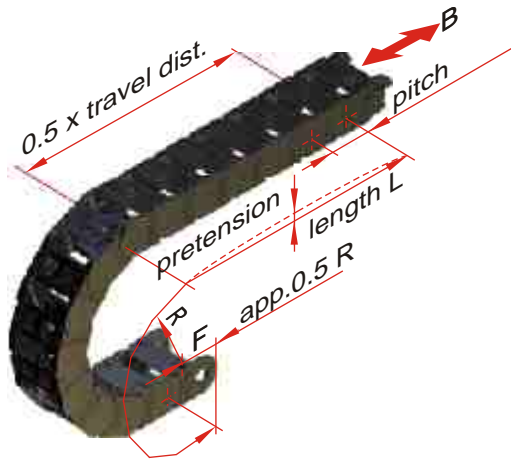
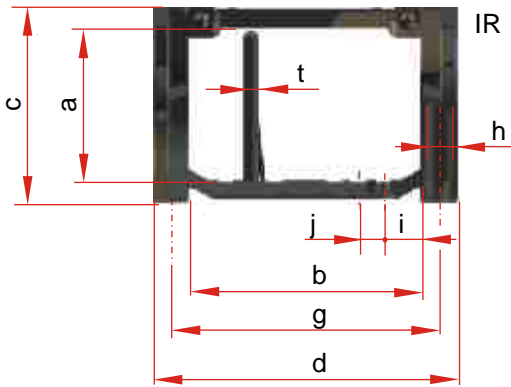

Kolibri c . d .type	prev. name		pitch	dimensions								weight kg/m	
				a	b	c	d	g	h	i ¹⁾	j ¹⁾		t ²⁾
10.012.4	00.3		15	Ø7	10	12	12	3	-	-	-	0.05	
13.023.4			20	9 14	13	23	19	3	-	-	-	0.12	
15.015.3	.4	0	0.3	20	Ø10	15	15	15	4	-	-	0.15	
15.036.5		02.5	18	10 25	15	36	30	4	-	-	-	0.30	
15.037.3			20	10 24	15	37	30	4	-	-	-	0.30	
15.051.0	03		20	10 39	15	51	44	4	-	-	-	0.35	
22.025.4	04.3		30	17 15	22	25	19,4	4	-	-	-	0.20	
22.038.0 .1	05.0		26	17 27	22	38	32.5	4	8	10	2	0.34	
22.048.0	06		30	17 36	22	48	41	4	13	10	2	0.37	
22.060.5		07.5	26	16 48	22	60	53	4	9,5	10	2	0.54	
30.030.3	1		40	24 18	30	30	23	4	-	-	-	0.50	
30.060.3	2		40	24 48	30	60	53	4	-	-	-	0.60	
30.050.0 .1	.5	10.0	10.5	35	23 34	30	50	40	5	9,5	5	3 ²⁾	0.54
30.060.0 .1	11.0		35	23 44	30	60	50	5	9,5	5	3	0.61	
30.080.0 .1 .2 .4 .5	12.0	12.5	35	23 64	30	80	70	5	9,5	5	3 ^{1),2)}	0.65	
30.095.0 .1	13.0		35	23 79	30	95	85	5	12	5	3	0.75	
30.125.0 .1	14.0		35	23 109	30	125	115	5	12	5	3	0.87	
40.062.2	.5	15.5	45	29 48	40	62	54	5	8	10	4	0.91	
40.075.2	.6		45	29 60	40	75	67	5	8	10	4	1.05	
40.112.7			37	31 50 ... 100		...124	5	5	5	3		1,05	
50.065.0	.5	21.0	21.5	55	40 48	50	65	55	6	9 ³⁾	9 ³⁾	2	1.30
50.095.0 .1 .2 .5	19.0	19.5	55	40 78	50	95	85	6	6,5 ³⁾	5 ³⁾	2	1.35	
50.125.0 .1	22.0		55	40 108	50	125	115	6	6,5	5	3	1.52	
50.150.0 .1	.5	20.0	20.5	55	40 133	50	150	140	6	6,5 ³⁾	5 ³⁾	3	1.90
65.095.1	.5	24.5	70	50 77	65	95	85	6	13,5	10	4	2.20	
65.135.1	.5	25.5	70	50 117	65	135	125	6	13,5	10	4	2.60	

1) not Kolibri *.2

2) for Kolibri *.2 is t=4 for Kolibri *.5 is t=2

3) for Kolibri *.5 is i=9,5 and j=10

Kolibri 00.000.0

standard type
flap open bars in inner radius
separable with pinch stay
integrated connector



Kolibri 00.000.1

openable in outer radius
flap open bars in outer radius
separable with pinch stay
integrated connector



Kolibri 00.000.2

rigid version
flap open bars in inner radius
separable with PZ
integrated connector



Kolibri 00.000.6
equal .2
flap open bars
in outer radius

Kolibri 00.000.3

one part chain links
not openable
not separable
integrated connector



Kolibri 00.000.4

film stay
film stay in inner radius
not separable
(integrated connector)



Kolibri 00.000.5

closed type
flap open covers in outer radius
separable with pinch stay
integrated connector



Kolibri

c . d .type	prev. name		radius							
			15	30	50	Kolibri 00.000.7 telescopic type PKK stays in inner radius separable via Pz separate connectors				
10.012.4	00.3		15	30	50					
13.023.4			17,5	35						
15.015.3	.4	0	0.3	17,5 ²⁾	20	30				
15.036.5			02.5	30	50					
15.037.3				24	30					
15.051.0	03			20	30					
22.025.4	04.3			35	70	100				
22.038.0 .1	05.0			35	50	60	70	100		
22.048.0	06			35	70					
22.060.5			07.5	50	70	100				
30.030.3	1			40	100	200				
30.060.3	2			40	100	150	200			
30.050.0 .1	.5	10.0	10.5	40 ¹⁾	60	75	100	150	200	
30.060.0 .1	11.0			40	50	75	100	150	200	
30.080.0 .1 .2 .4 .5	12.0		12.5	40 ¹⁾	60 ⁴⁾	75	100	150	200	
30.095.0 .1	13.0			40	75	100	125	150	200	
30.125.0 .1	14.0			40	75	100	150	200		
40.062 .2	.5	15.5		60 ¹⁾	75	100	150	200		
40.075.2	.6			60	75	100	150	200		
40.112.7				55						
50.065.0	.5	21.0	21.5	75 ¹⁾	100	125 ¹⁾	150	200		
50.095.0 .1 .2 .5	19.0		19.5	75 ¹⁾	100	125 ¹⁾	150	175 ¹⁾	200	
50.125.0 .1	22.0			75	100	125	150	200		
50.150.0 .1	.5	20.0	20.5	75 ¹⁾	100	150	200			
65.095.1	.5	24.1	24.5				125	150	200	
65.135.1	.5	25.5					125	150	200	
65.195.1	.5	27.5					125	150	200	

1) not Kolibri xx.xxx.5

2) only Kolibri 15.015.3

4)only Kolibri 30.080.5

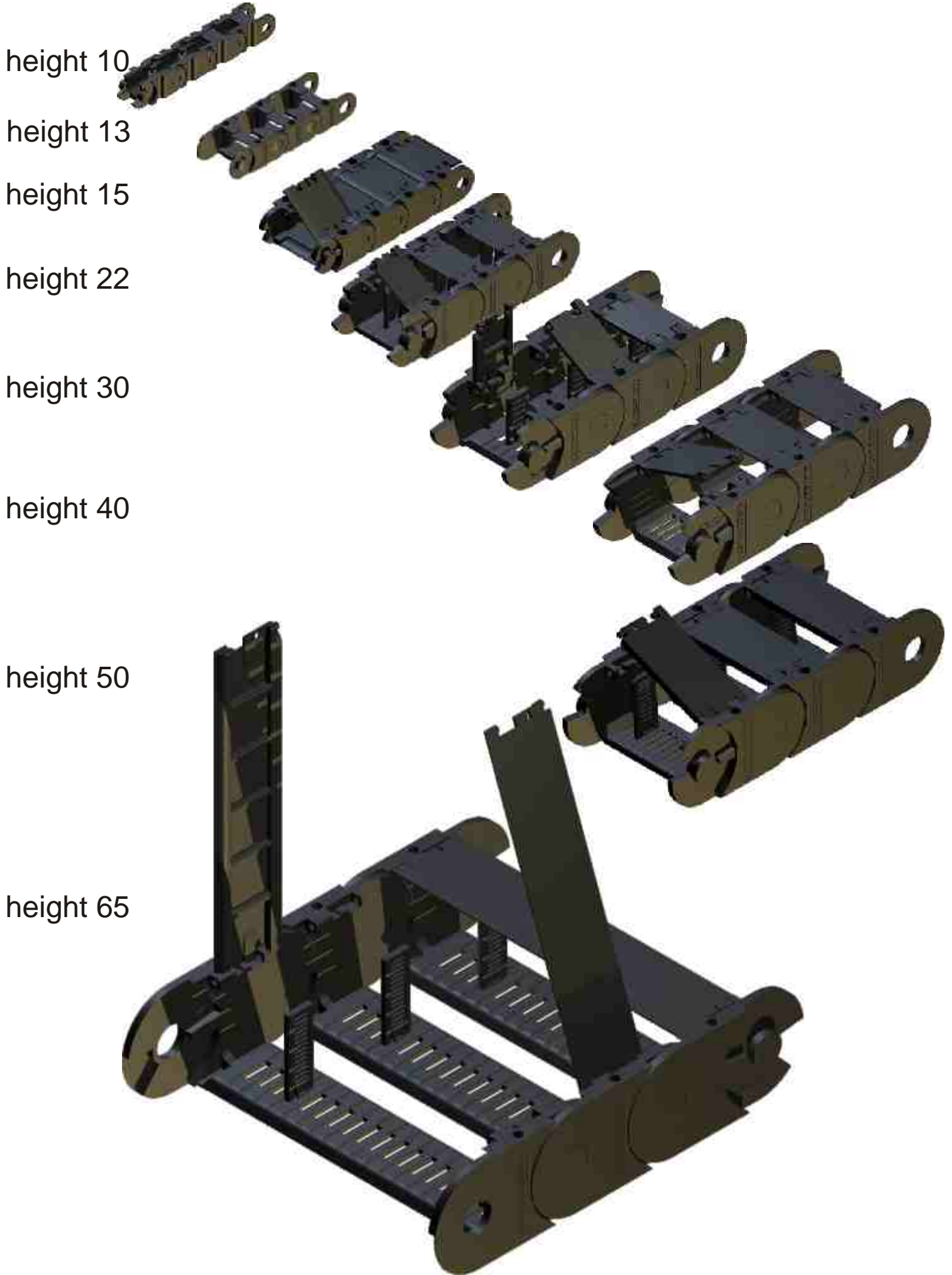

Kolibri HEIGHT 10

inner height 7 up to 8, inner width 7 up to 14

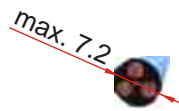

Kolibri 10.012.4

one part link
film stay in inner radius
integrated connector or separate connectors
space (axb): **Ø7 not separable**
bend radius: 15 / 30 / 50
weight: 0,05 kg/m
free carrying length: 0.4 m at 0.3 kg/m load
pitch: 15

order example:

Kolibri 10.012.4 / 50 x 1005

type / radius x length

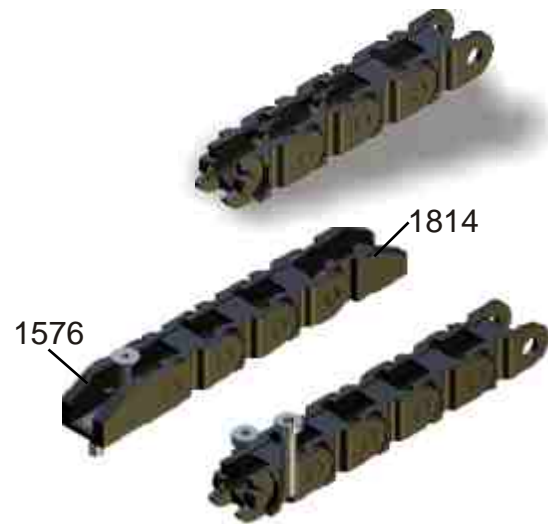

Kolibri 13.023.4

one part link
fether stay in inner radius
integrated connector
space (axb): **8x14 not separable**
bend radius: 17,5 / 35 / 55 / 80 / 100
weight: 0,12 kg/m
free carrying length: 0,8 m at 0.5 kg/m load
pitch: 20

order example:

Kolibri 10.012.4 / 50 x 1005

type / radius x length

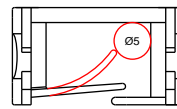

fether stay long
max.Ø5mm

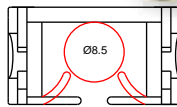

fether stay short
Max.Ø8.5mm



Snap

(see page 26,32,39,41)





Kolibri HEIGHT 15

inner height 10, inner width 10 to 39

Kolibri 15.015.3

one part chain link
 not openable
 connector as separate part (part.no. 0700)
space (axb): Ø10 not separable
 bend radius: 17.5 / 20 / 30
 weight: 0.15 kg/m
 free carrying length: 0,9.m at 0.9 kg/m load
 pitch: 20

order example:

Kolibri 15.015.3 / 30 x 1000

type / radius x length



Kolibri 15.015.4

one part chain link
 film-stay in inner radius
 connector as separate part (see Kolibri 15.015.3)
space (axb): Ø10 not separable
 bend radius: 20 / 30
 weight: 0.15 kg/m
 free carrying length: 0.9 m at 0.9 kg/m load
 pitch: 20

order example:

Kolibri 15.015.4 / 30 x 1000

type / radius x length

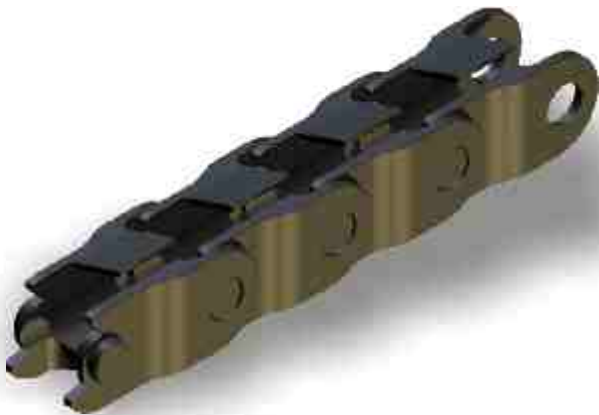

Kolibri 15.036.5

closed type
 flap covers in outer radius
 integrated connectors
space (axb): 10 x 25 not separable
 bend radius: 30 / 50
 weight: 0.3 kg/m
 free carrying length: 0.9m at 0.9 kg/m load
 pitch: 18

order example:

Kolibri 15.036.5 / 30 x 1008

type / radius x length



Kolibri HEIGHT 15

inner height 10, inner width 10 to 39

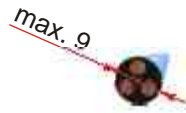

Kolibri 15.037.3

one part chain link
not openable, closed in outer radius
integrated connectors

Space (axb): 10 x 24 not separable
bend radius: 24, 30
weight: 0.3 kg/m
free carrying length: 0.9 at 0.9 kg/m load
pitch: 20

order example:

Kolibri 15.037.3 / 30 x 1000

type / radius x length



Kolibri 15.051.0

standard type
flap stay in inner radius
integrated connectors

space (axb): 10 x 39 not separable
bend radius: 20 / 30
weight: 0.35 kg/m
free carrying length: 0.9 m at 0.9 kg/m load
pitch: 20

order example:

Kolibri 15.051.0 / 30 x 1000

type / radius x length

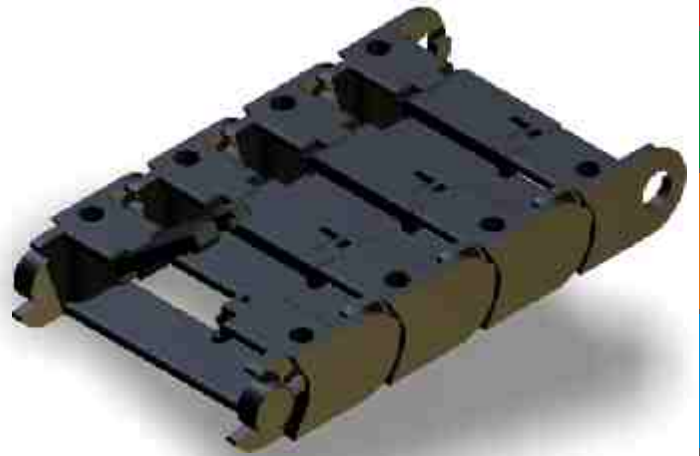

Kolibri HEIGHT 22

inner height 16 to 22, inner width 15 to 48

Kolibri 22.025.4

one part chain link
film stay
integrated connectors

space (axb): **17 x 15 not separable**
 bend radius: 35 / 70 / 100
 weight: 0.20 kg/m
 free carrying length: 1.3 m at 1.5 kg/m load
 pitch: 30

order example:

Kolibri 22.025.4 / 35 x 1020

type / radius x length

Kolibri 22.038.0

standard type
flap stay in inner radius
integrated connectors

space (axb): **17 x 27 separable (PZ ANr.1688)**
 bend radius: 35 / 50 / 70 / 100
 weight: 0.34 kg/m
 free carrying length: 1.5 m at 1.0 kg/m load
 pitch: 26

order example:

Kolibri 22.038.0 / 35 x 1040

type / radius x length

Snap

Assembly example:

Kolibri 22.038.0 is available with Snap connectotr:

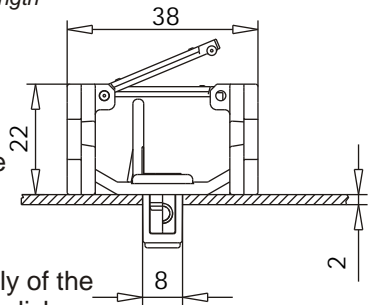

Quick and toolless assembly of the energy chain with only one click.

Please contact the ekd gelenkrohr design department.

Kolibri 22.038.1

open type
flap stay in outer radius
integrated connectors

space (axb): **17 x 27 separable (PZ ANr.1688)**
 bend radius: 35
 weight: 0.34 kg/m
 free carrying length: 1.5 m at 1.0 kg/m load
 pitch: 26

order example:

Kolibri 22.038.1 / 35 x 1040

type / radius x length

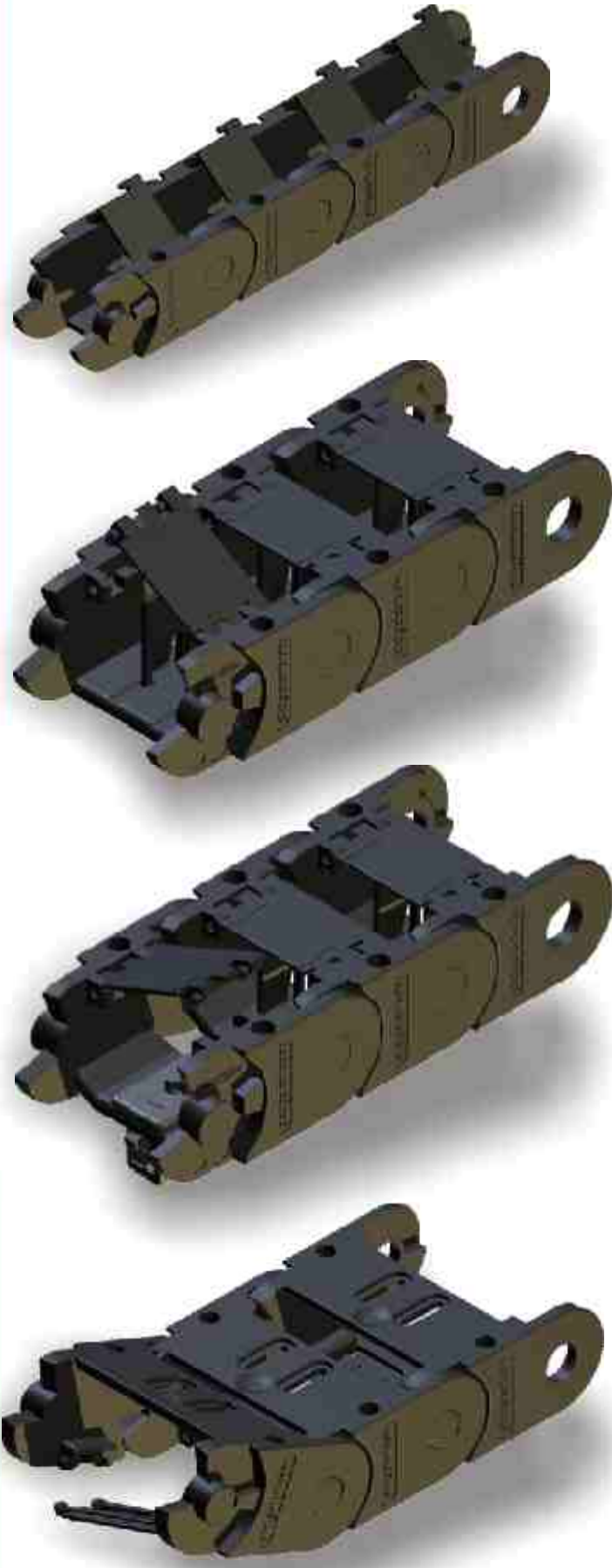

Kolibri HEIGHT 22

inner height 16 to 22, inner width 15 to 48

max. 14-20

Kolibri 22.048.0

open type
flap stay in inner radius
integrated connectors

space (axb): 17 x 36 not separable
bend radius: 35 / 70
weight: 0.37 kg/m
free carrying length: 1.3 m at 1.5 kg/m load
pitch: 30

order example:

Kolibri 22.048.0 / 35 x 1200

type / radius x length

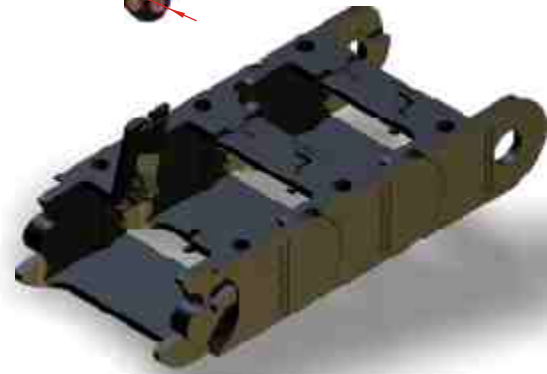

Kolibri 22.060.5

closed type
flap stay in outer radius
integrated connectors

space (axb): 16 x 48 separable (PZ ANr.1294)
bend radius: 50 / 70 / 100
weight: 0.54 kg/m
free carrying length: 1.3 m at 1.5 kg/m load
pitch: 26

order example:

Kolibri 22.060.5 / 100 x 1014

type / radius x length





Kolibri HEIGHT 30

inner height 23 to 24, inner width 18 to 109

Kolibri 30.030.3

one part chain link
not openable
integrated connectors

space (axb): **24 x 18 not separable**
 bend radius: 40 / 100 / 200
 weight: 0.50 kg/m
 free carrying length: 1.5 m at 2.0 kg/m load
 pitch: 40

order example:

Kolibri 30.030.0 / 100 x 1200

type / radius x length



Kolibri 30.050.0

standard type
flap stay in inner radius
integrated connectors

space (axb): **23 x 34 separable (PZ ANr.1258)**
 bend radius: 40 / 60 / 75 / 100 / 150 / 200
 weight: 0.54 kg/m
 free carrying length: 1.5 m at 2.0 kg/m load
 pitch: 35

order example:

Kolibri 30.050.0 / 100 x 1225

type / radius x length

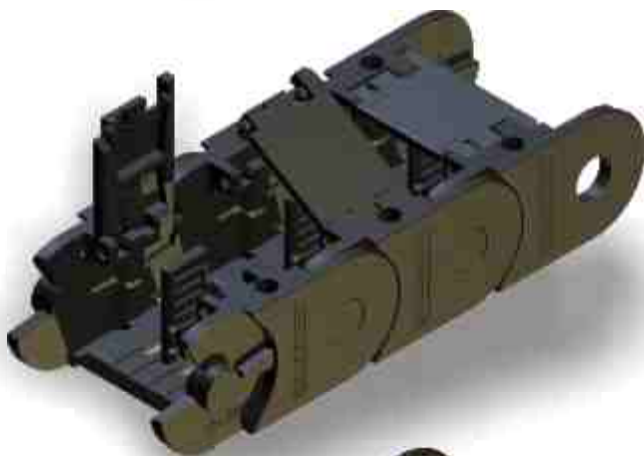

Kolibri 30.050.1

open type
flap stay in outer radius
integrated connectors

space (axb): **23 x 34 separable (PZ ANr.1258)**
 bend radius: 40 / 60 / 75 / 100 / 150 / 200
 weight: 0.54 kg/m
 free carrying length: 1.5 m at 2.0 kg/m load
 pitch: 35

order example:

Kolibri 30.050.1 / 100 x 1225

type / radius x length

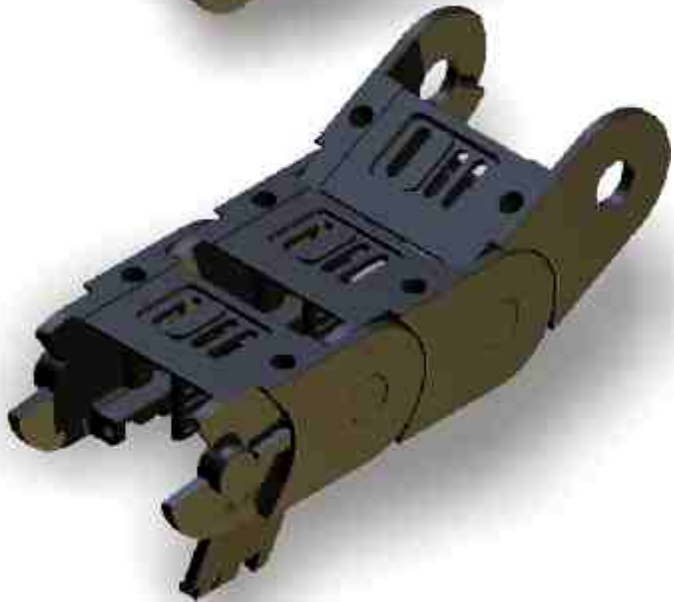

Kolibri 30.050.5

closed type
flap covers in outer radius
integrated connectors

space (axb): **23 x 34 separable (PZ ANr.1017)**
 bend radius: 60 / 75 / 100 / 150 / 200
 weight: 0.58 kg/m
 free carrying length: 1.5 m at 2.0 kg/m load
 pitch: 35

order example:

Kolibri 30.050.5 / 100 x 1225

type / radius x length



Kolibri HEIGHT 30

inner height 23 to 24, inner width 18 to 109

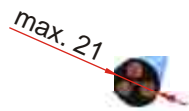

Kolibri 30.060.0

standard type
flap stay in inner radius
integrated connectors

space (axb): 23 x 44 separable (PZ ANr.1258)
bend radius: 40 / 50 / 75 / 100 / 150 / 200
weight: 0.61 kg/m
free carrying length: 1.5 m at 2.0 kg/m load
pitch: 35

order example:

Kolibri 30.060.0 / 100 x 1225

type / radius x length

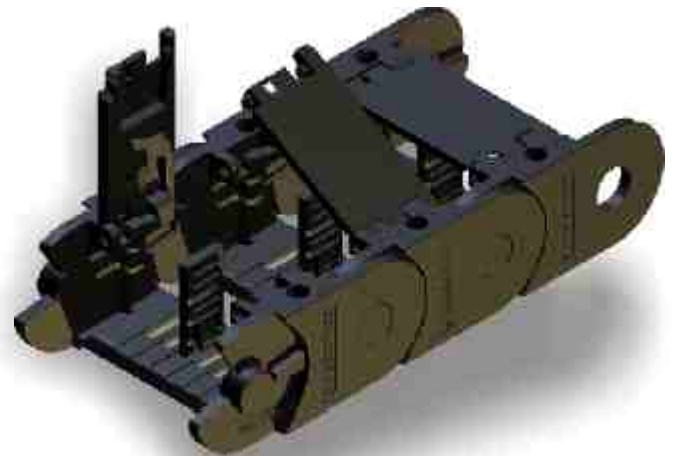

Kolibri 30.060.1

open type
flap stay in outer radius
integrated connectors

space (axb): 23 x 44 separable (PZ ANr.1258)
bend radius: 40 / 50 / 75 / 100 / 150 / 200
weight: 0.61 kg/m
free carrying length: 1.5 m at 2.0 kg/m load
pitch: 35

order example:

Kolibri 30.060.1 / 100 x 1225

type / radius x length

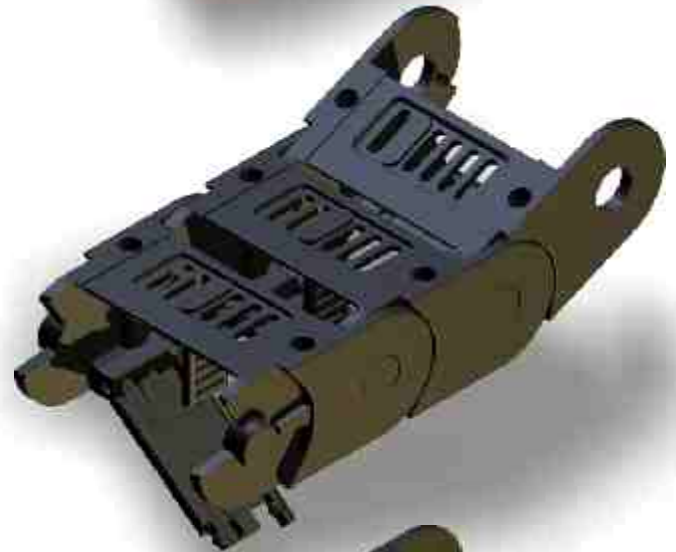

Kolibri 30.060.3

open type
not openable
integrated connectors

space (axb): 24 x 48
bend radius: 40 / 100 / 150 / 200
weight: 0.60 kg/m
free carrying length: 1.5 m at 2.0 kg/m load
pitch: 40

order example:

Kolibri 30.060.3 / 100 x 1200

type / radius x length

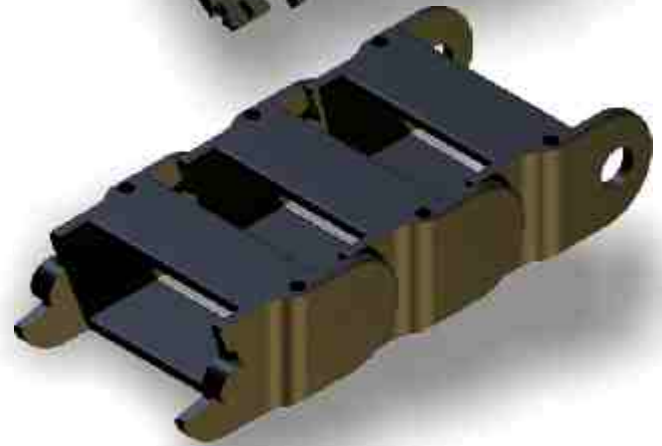

Kolibri 30.080.0

standard type
flap stay in inner radius
integrated connectors

space (axb): 23 x 64 separable (PZ ANr.1258)
bend radius: 40 / 75 / 100 / 150 / 200
weight: 0.65 kg/m
free carrying length: 1.5 m at 2.0 kg/m load
pitch: 35

order example:

Kolibri 30.080.0 / 100 x 1225

type / radius x length

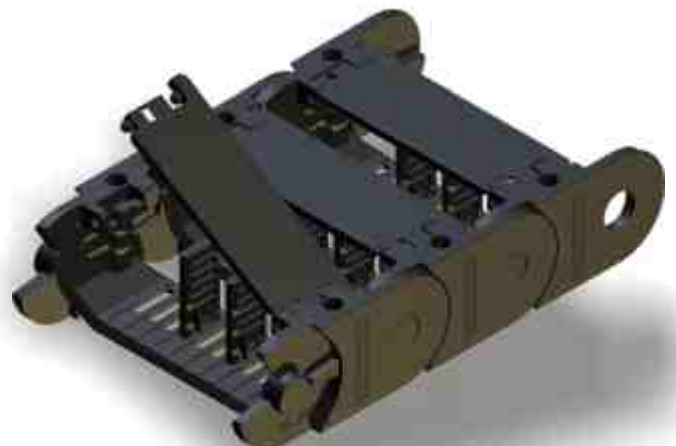



Kolibri HEIGHT 30

inner height 23 to 24, inner width 18 to 109

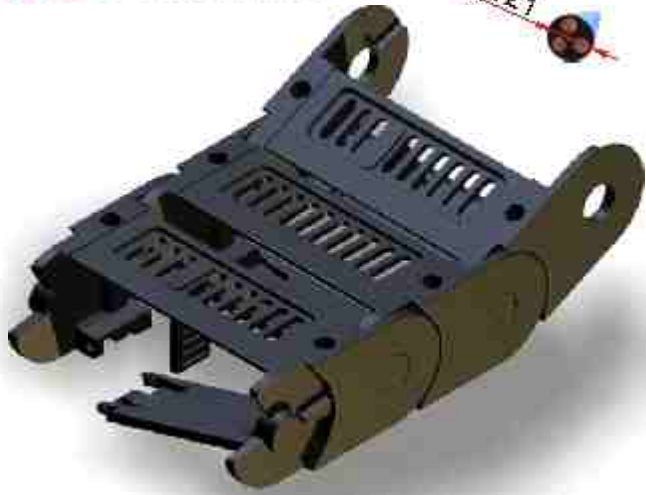

Kolibri 30.080.1

standard type
flap stay in outer radius
integrated connectors

space (axb): **23 x 64 separable (PZ ANr.1258)**
 bend radius: 40 / 75 / 100 / 150 / 200
 weight: 0.65 kg/m
 free carrying length: 1.5 m at 2.0 kg/m load
 pitch: 35

order example:

Kolibri 30.080.0 / 100 x 1225

type / radius x length



Kolibri 30.080.2

rigid type
flap stay in inner radius
integrated connectors

space (axb): **21 x 64 not separable**
 bend radius: 40 / 75 / 100 / 150 / 200
 weight: 0.7 kg/m
 free carrying length: 1.5 m at 2.0 kg/m load
 pitch: 35

order example:

Kolibri 30.080.2 / 100 x 1225

type / radius x length

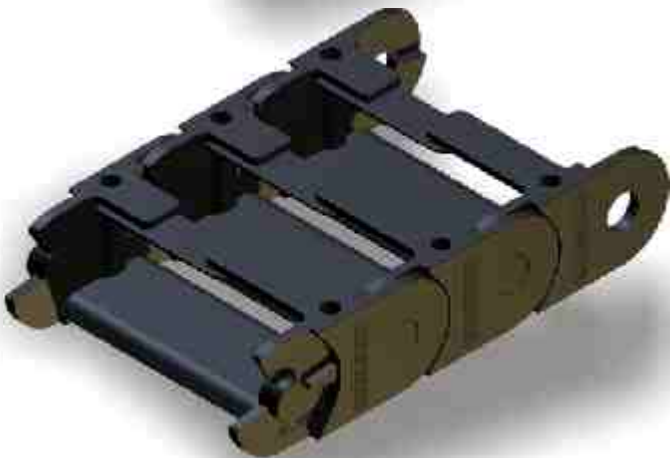

Kolibri 30.080.4

one part chain link
lining without assembly
integrated connectors

space (axb): **21 x 64 not separable**
 bend radius: 40 / 75 / 100 / 150 / 200
 weight: 0.65 kg/m
 free carrying length: 1.5 m at 2.0 kg/m load
 pitch: 35

order example:

Kolibri 30.080.4 / 100 x 1225

type / radius x length



Kolibri 30.080.5

closed type
flap covers in outer radius
integrated connectors

space (axb): **23 x 64 separable (PZ ANr.1017)**
 bend radius: 60 / 75 / 100 / 150 / 200
 weight: 0.7 kg/m
 free carrying length: 1.5 m at 2.0 kg/m load
 pitch: 35

order example:

Kolibri 30.080.5 / 100 x 1225

type / radius x length

Kolibri HEIGHT 30

inner height 23 to 24, inner width 18 to 109

max. 21

Kolibri 30.095.0

standard type
flap stays in inner radius
integrated connectors

space (axb): 23 x 79 separable (PZ ANr.1258)
bend radius: 40 / 75 / 100 / 125 / 150 / 200
weight: 0.75 kg/m
free carrying length: 1.5 m at 2.0 kg/m load
pitch: 35

order example:

Kolibri 30.095.0 / 100 x 1225

type / radius x length

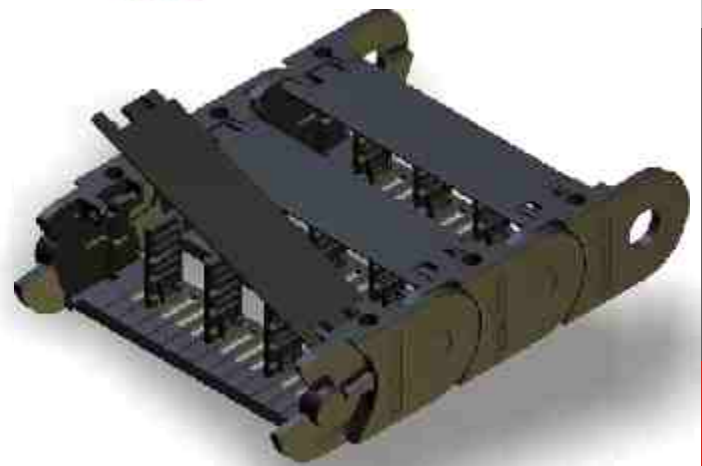

Kolibri 30.095.1

open type
flap stays in outer radius
integrated connectors

space (axb): 23 x 79 separable (PZ ANr.1258)
bend radius: 40 / 75 / 100 / 125 / 150 / 200
weight: 0.75 kg/m
free carrying length: 1.5 m at 2.0 kg/m load
pitch: 35

order example:

Kolibri 30.095.1 / 100 x 1225

type / radius x length

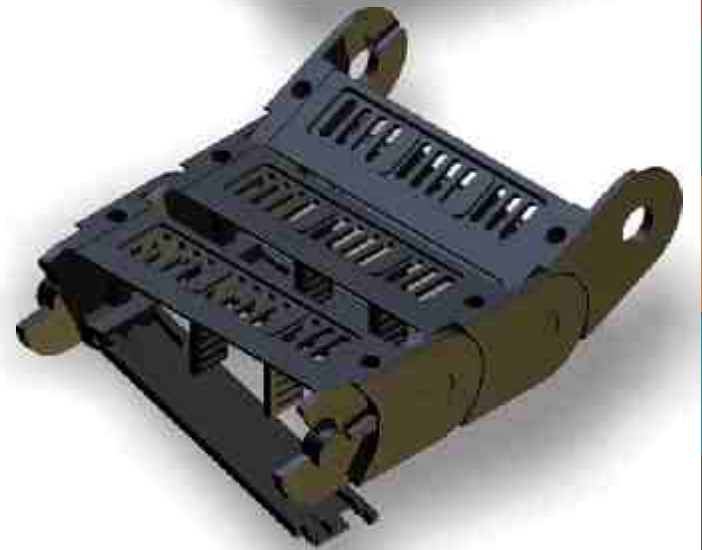

Snap

toolless assembly
of the chain



Kolibri HEIGHT 30

inner height 23 to 24, inner width 18 to 109

Kolibri 30.125.0

standard type
flap stay in inner radius
integrated connectors

space (axb): **23 x 109 separable (PZ ANr.1258)**
 bend radius: 40 / 75 / 100 / 150 / 200
 weight: 0.87 kg/m
 free carrying: 1.5 m at 2.0 kg/m load
 pitch: 35

order example:

Kolibri 30.125.0 / 100 x 1225

type / radius x length

Kolibri 30.125.1

open type
flap stay in outer radius
integrated connectors

space (axb): **23 x 109 separable (PZ ANr.1258)**
 bend radius: 40 / 75 / 100 / 150 / 200
 weight: 0.87 kg/m
 free carrying: 1.5 m at 2.0 kg/m load
 pitch: 35

order example:

Kolibri 30.125.1 / 100 x 1225

type / radius x length

Kolibri with Snap

Type Kolibri allows using the Snap connector:
 Fast and toolless assembly of the energy chain with only one click.
 Please contact ekd gelenkrohr technic during your Planing phase.

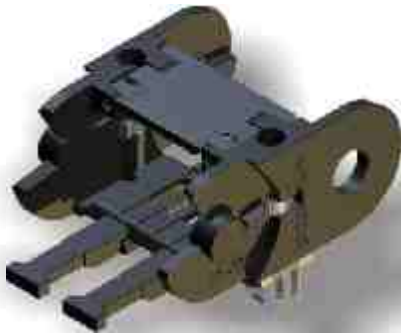
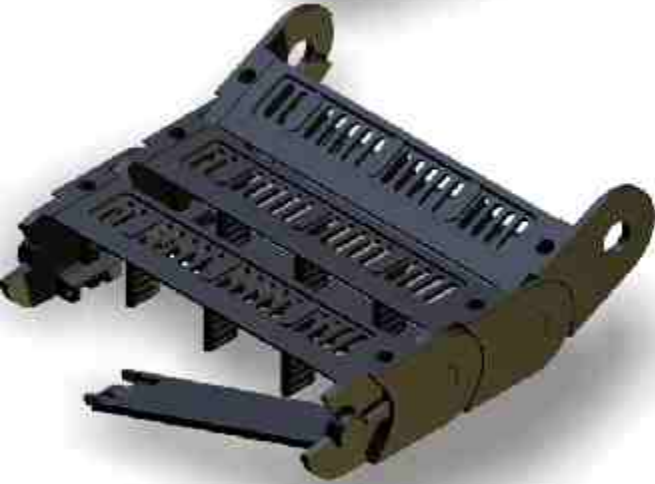

assembly example:

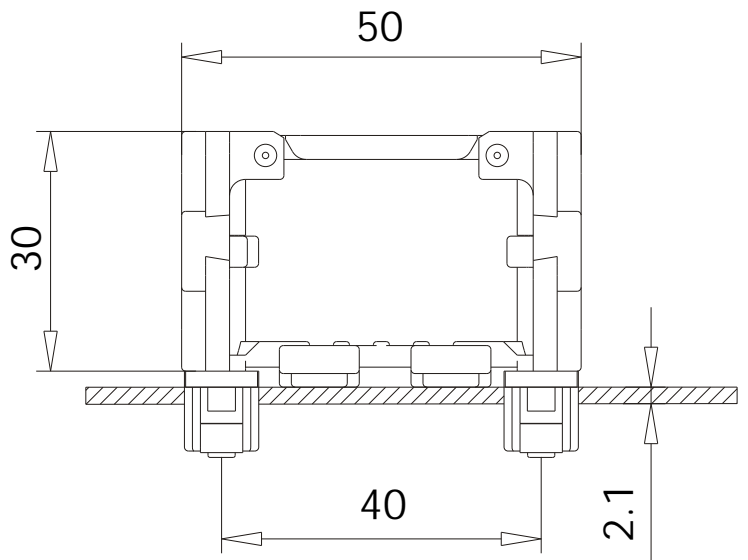
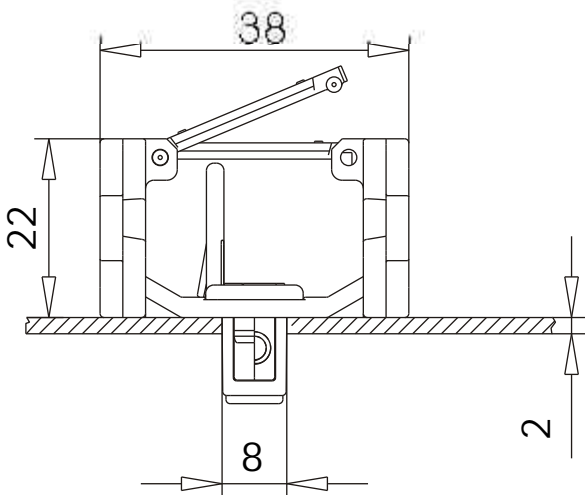

Kolibri HEIGHT 40

inner height 31, inner width 48 to 60



Kolibri 40.062.2

rigid type
flap stay in inner radius
integrated connectors

space (axb): 29 x 48 separable (PZ ANr.1521)
bend radius: 60 / 75 / 100 / 150 / 200
weight: 0.91 kg/m
free carrying length: 2.0 m at 1.0 kg/m load
pitch: 45

order example:

Kolibri 40.062.2 / 100 x 1260

type / radius x length

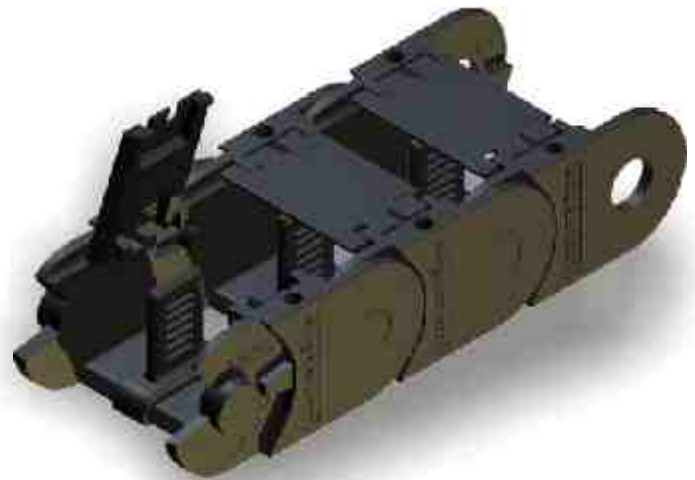

Kolibri 40.062.5

closed type
flap covers in outer radius
integrated connectors

space (axb): 29 x 48 separable (PZ ANr.1268)
bend radius: 75 / 100 / 150 / 200
weight: 0.93 kg/m
free carrying length: 2.0 m at 1.0 kg/m load
pitch: 45

order example:

Kolibri 40.062.5 / 100 x 1260

type / radius x length



max. 27 

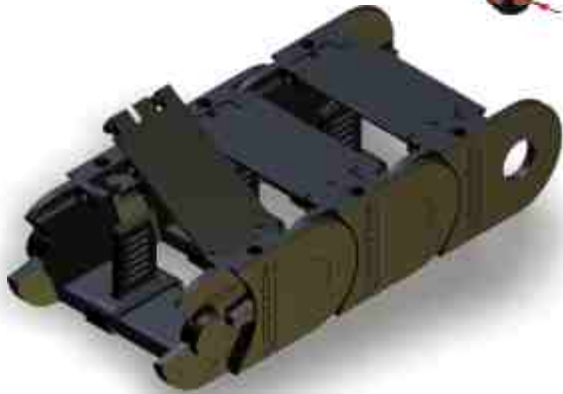

Kolibri HEIGHT 40

inner height 31, inner width 48 to 60

Kolibri 40.075.2

rigid type
 flap stay in inner radius
 integrated connectors
space (axb): 29 x 60 separable (PZ ANr.1521)
 bend radius: 60 / 75 / 100 / 150 / 200
 weight: 1.05 kg/m
 free carrying length: 2.0 m at 1.0 kg/m load
 pitch: 45

order example:

Kolibri 40.075.2 / 100 x 1260

type / radius x length



Kolibri 40.075.6

rigid type
 flap stay in outer radius
 integrated connectors
space (axb): 29 x 60 separable (PZ ANr.1521)
 bend radius: 60 / 75 / 100 / 150 / 200
 weight: 1.05 kg/m
 free carrying length: 2.0 m at 1.0 kg/m load
 pitch: 45

order example:

Kolibri 40.075.6 / 100 x 1260

type / radius x length

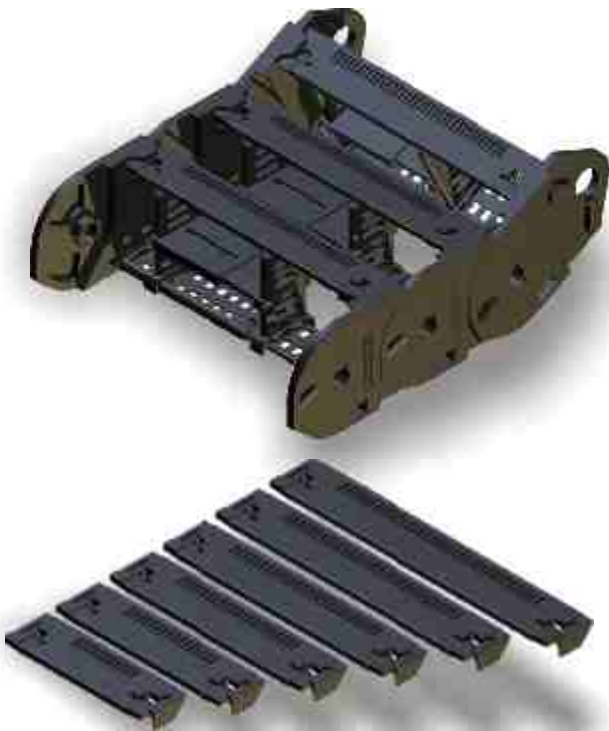

Kolibri 40.112.7

telescopic type
 PKK stay in inner radius
 separate connector
space (axb): 31x100 separable (PZ ANr.2035)
 bend radius: 55 / 100 / 150 / 200 / 230
 weight: 0,9 kg/m
 free carrying length: 2,5 at 1,0 kg/m load
 pitch: 37

order example:

Kolibri 40.112.7 / 55 x 1295 / 100

type / radius x length / stay length

stay length 50 up to 100

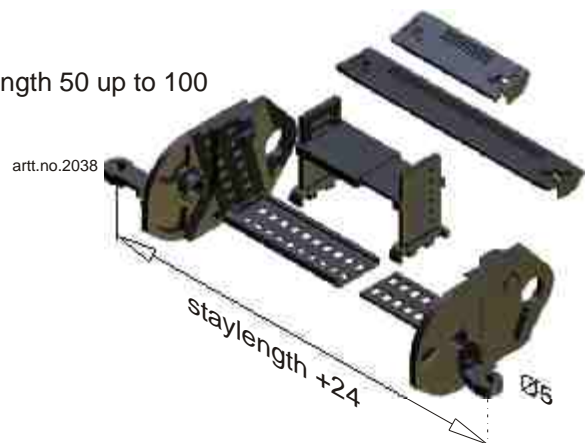

Kolibri HEIGHT 50

inner height 38 to 40, inner width 48 to 134



Kolibri 50.065.0

standard type
flap stay in inner radius
integrated connectors

space (axb): 40 x 48 separable (PZ ANr.1113)
bend radius: 75 / 100 / 125 / 150 / 200 / 250
weight: 1.30 kg/m
free carrying: 2.4 m at 1.0 kg/m load
pitch: 55

order example:

Kolibri 50.065.0 / 100 x 1265

type / radius x length



Kolibri 50.065.5

colsed type
flap covers in outer radius
integrated connectors

space (axb): 40 x 48 separable (PZ ANr.1113)
bend radius: 100 / 150 / 200 / 250
weight: 1.30 kg/m
free carrying length: 2.4 m at 1.0 kg/m load
pitch: 55

order example:

Kolibri 50.065.5 / 100 x 1265

type / radius x length



Kolibri 50.095.0 50.095.1

standard type
flap stay in inner radius flap stay in outer radius
integrated connectors

space (axb): 40 x 78 separable (PZ ANr.1113)
bend radius: 75/100/ 125/ 150/ 175/ 200/ 250
weight: 1.35 kg/m
free carrying length: 2.4 m at 1.0 kg/m load
pitch: 55

order example:

Kolibri 50.095.0 / 100 x 1265

type / radius x length

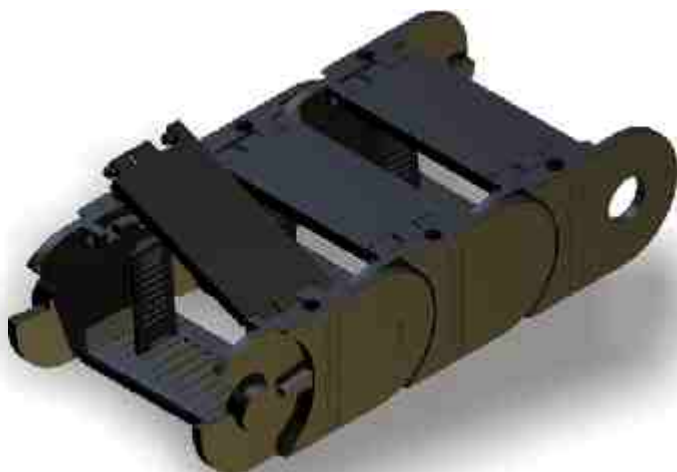

Kolibri 50.095.2

rigid type
flap stay in inner radius
integrated connectors

space (axb): 38 x 78 separable (PZ ANr.1451)
bend radius: 75/100/ 125/ 150/ 175/ 200/ 250
weight: 1.40 kg/m
free carrying length: 2.4 m at 1.0 kg/m load
pitch: 55

order example:

Kolibri 50.095.2 / 100 x 1265

type / radius x length

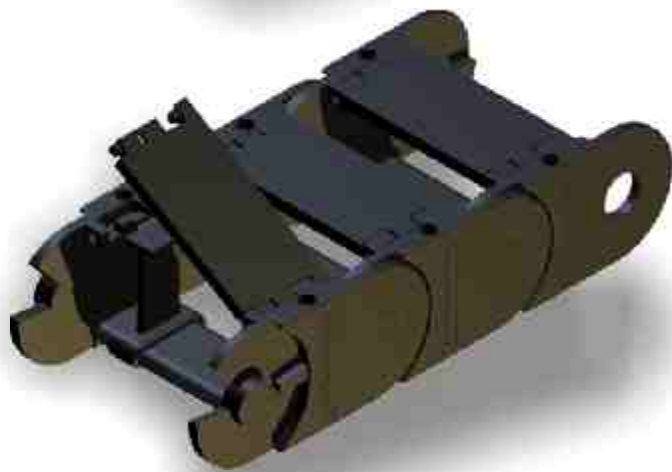

max. 36 

Kolibri HEIGHT 50

inner height 38 to 40, inner width 48 to 134

Kolibri 50.095.5

closed type
flap stay in outer radius
integrated connectors

space (axb): 40 x 78 separable (PZ ANr.1113)
bend radius: 100/ 125/ 150/ 175/ 200/ 250
weight: 1.40 kg/m
free carrying length: 2.4 m at 1.0 kg/m load
pitch: 55

order example:

Kolibri 50.095.5 / 100 x 1265

type / radius x length

Kolibri 50.125.0 50.125.1

standard type
flap stay in inner radius flap stay in outer radius
Integrated connectors

space (axb): 40 x 108 separable (PZ ANr.1326)
bend radius: 75 / 100 / 125 / 150 / 200 / 250
weight: 1.52 kg/m
free carrying length: 2.4 m at 1.0 kg/m load
pitch: 55

order example:

Kolibri 50.125.0 / 100 x 1265

type / radius x length

Kolibri 50.150.0 50.150.1

standard type
flap stay in inner radius flap stay in outer radius
integrated connectors

space (axb): 40 x 133 separable (PZ ANr.1326)
bend radius: 75 / 100 / 150 / 200 / 250
weight: 1.90 kg/m
free carrying length: 2.4 m at 1.0 kg/m load
pitch: 55

order example:

Kolibri 50.150.0 / 100 x 1265

type / radius x length

Kolibri 50.150.5

closed type
flap stay in outer radius
integrated connectors

space (axb): 40 x 133 separable (PZ ANr.1113)
bend radius: 75 / 100 / 150 / 200 / 250
weight: 1.90 kg/m
free carrying length: 2.4 m at 1.0 kg/m load
pitch: 55

order example:

Kolibri 50.150.5 / 100 x 1265

type / radius x length

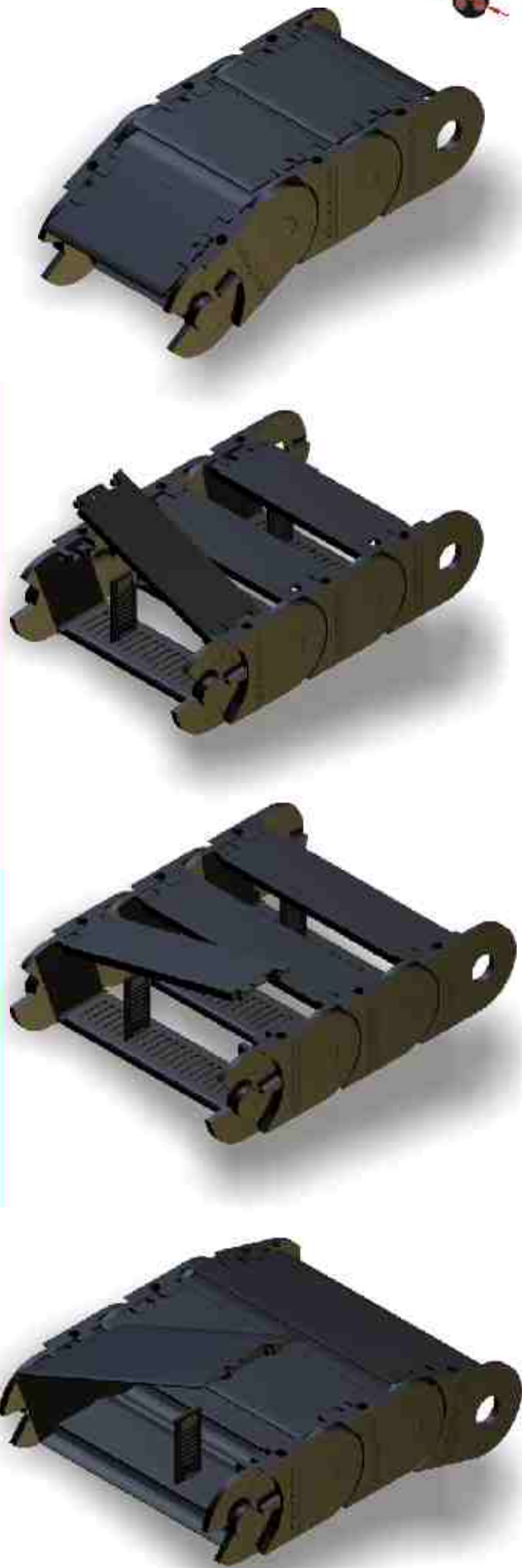

Kolibri HEIGHT 65

inner height 50, inner width 77 to 205

max. 45



EKD SYSTEMS

Content

Kolibri 65.095.1

open type
flap stay in outer radius
integrated connectors

space (axb): 50 x 77 separable (PZ ANr.1129)
bend radius: 125 / 150 / 200 / 300
weight: 2.2 kg/m
free carrying length: 2.75 m at 1.0 kg/m load
pitch: 70

order example:

Kolibri 65.095.1 / 125 x 1400

type / radius x length



Kolibri 65.095.5

closed type
flap cover in outer radius
integrated connectors

space (axb): 50 x 77 separable (PZ ANr.1129)
bend radius: 125 / 150 / 200 / 300
weight: 2.2 kg/m
free carrying length: 2.75 m at 1.0 kg/m load
pitch: 70

order example:

Kolibri 65.095.5 / 125 x 1400

type / radius x length



Kolibri 65.135.1

open type
flap stay in outer radius
integrated connectors

space (axb): 50 x 117 separable (PZ ANr.1129)
bend radius: 125 / 150 / 200 / 300 / 400
weight: 2.6 kg/m
free carrying length: 2.75 m at 1.0 kg/m load
pitch: 70

order example:

Kolibri 65.135.1 / 125 x 1400

type / radius x length



Kolibri 65.135.5

closed type
flap cover in outer radius
integrated connectors

space (axb): 50 x 117 separable (PZ ANr.1129)
bend radius: 125 / 150 / 200 / 300 / 400
weight: 2.7 kg/m
free carrying length: 2.75 m at 1.0 kg/m load
pitch: 70

order example:

Kolibri 65.135.1 / 125 x 1400

type / radius x length



Design guidelines

Order infos

Kolibri

PKK

PLP PLA

PLE

SLP SLA

SLE

GKA

SFK

PFR

Troughs

Systems

Materials

Information

ETIOLA

ETIOLA

ETIOLA

ETIOLA

ETIOLA

ETIOLA

ETIOLA



Kolibri HEIGHT 65

inner height 50, inner width 77 to 205



Kolibri 65.195.1

- open type
- flap stay in outer radius
- integrated connectors
- space (axb): **50 x 177 separable (PZ ANr.1129)**
- bend radius: 125 / 150 / 200 / 300
- weight: 2.9 kg/m
- free carrying length: 2.75 m at 1.0 kg/m load
- pitch: 70

order example:

Kolibri 65.195.1 / 125 x 1400

type / radius x length



Kolibri 65.195.5

- closed type
- flap cover in outer radius
- integrated connectors
- space (axb): **50 x 177 separable (PZ ANr.1129)**
- bend radius: 125 / 150 / 200 / 300
- weight: 3.0 kg/m
- free carrying length: 2.75 m at 1.0 kg/m load
- pitch: 70

order example:

Kolibri 65.195.5 / 125 x 1400

type / radius x length

- | Pos. | name |
|------|----------------------------------|
| 1 | link (open type) |
| 2 | link (closed type) |
| 3 | flange pivot |
| 4 | flange drilling |
| 5 | horn stay connector |
| 6 | horn stay 65 HS65 |
| 7 | horn stay 85 HS 85 |
| 8 | damping element |
| 9 | PZ (divider) |
| 10 | PZ (pinch stay) |
| 11 | flap stay |
| 12 | flap cover |
| 13 | notched horizontal divider |
| 14 | notched horiz. divider flying |
| 15 | telescopic horizontal divider |
| 16 | telescopic horiz. divider flying |
| 17 | ladderstay |
| 20 | connector 10.012.4 hole |
| 21 | connector 10.012.4 pivot |

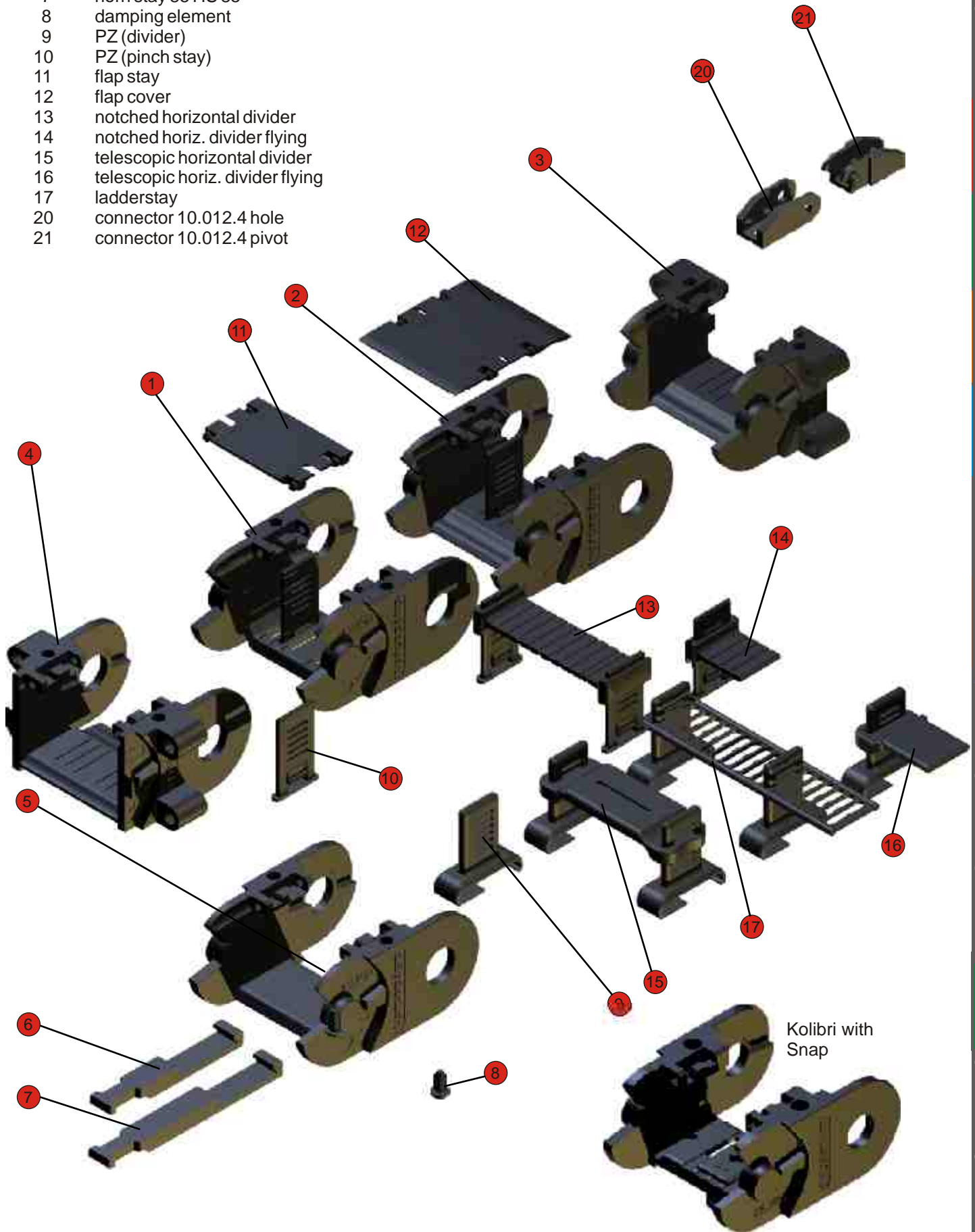

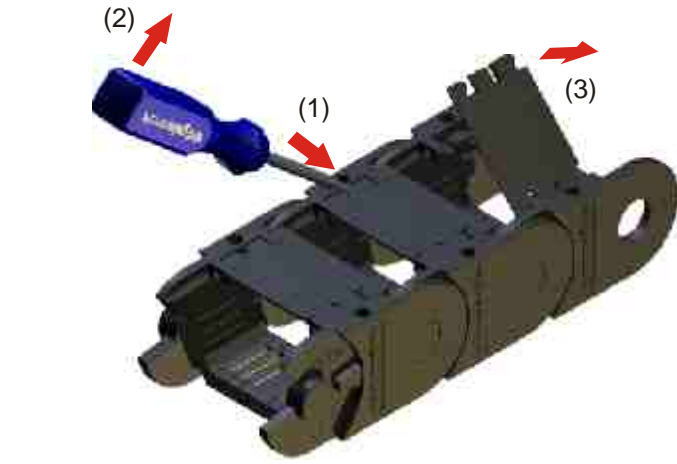

Opening and closing

Push a screwdriver as shown in the the slot (1) then with a light lever movement (2) raise the tongue and push the locking pins of the flap stay (or the flap cover) out of the drilling. The flap stay can then be lifted (3). To remove the flap stay the second side has to be unlocked and the stay has to be pushed out against the direction of the cones.

The installation of the flap stays and flap covers are snapped in a slight angle with the pins against the corresponding drillings (4) and with slight pressure against the locking tongue.

Lifted flap stays can be re-engaged (5) with slight pressure.

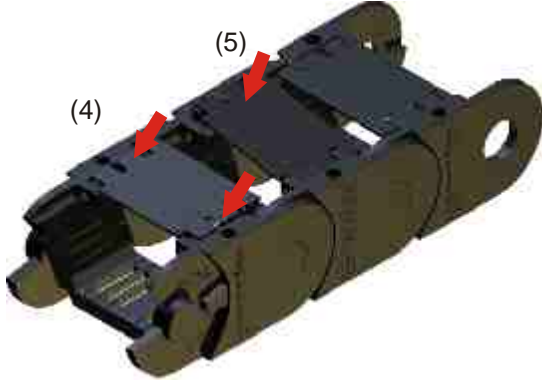

Lengthening and shortening

To lengthen or shorten the flap stays have to be opened. The walls with pivot pins are to press internally (1) and the walls with the holes are to press toward the outside (2). The chain links can be pushed together (3), or be pulled apart.

Installation of the flap stays

The assembly of the flap stays can take place before or after cable lining. Therefore energy chain does not need to be opened. The flap stays are inserted from the outside chain link floor until snap (1), (2). The dismantling of the stays is done by unlocking the tongue and pushing out (3).

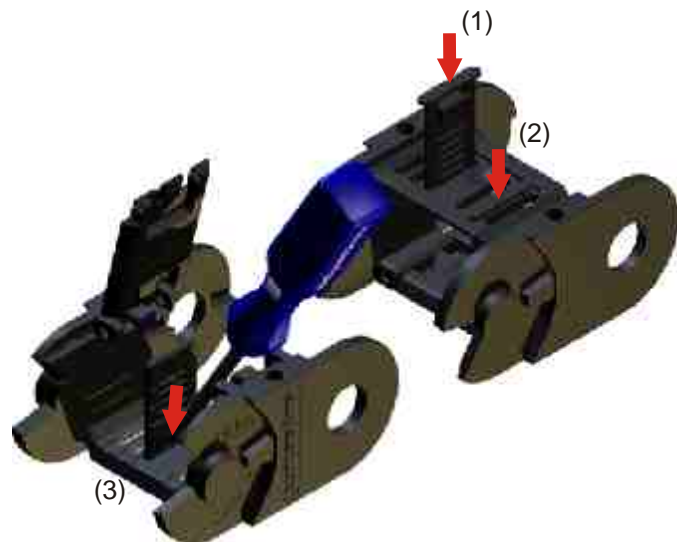
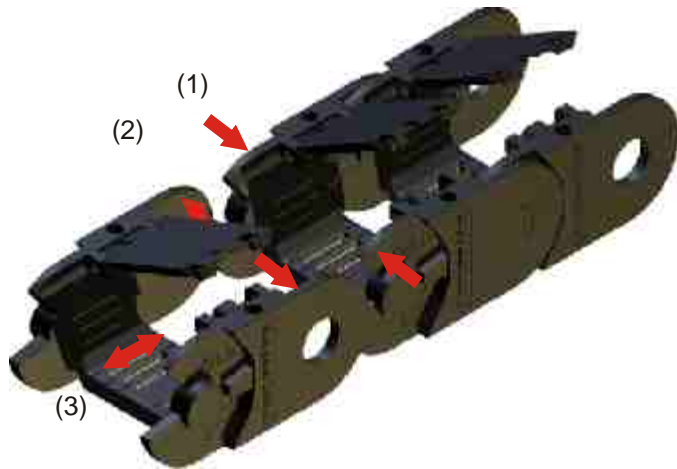

Assembly of horizontal dividers

The horizontal dividers (notched, telescopic and ladder-stay) are horizontally slid onto the vertical dividers (PZ) (1).

With a screwdriver the locking tongue can be mounted (2) and horizontal dividers disassembled (3).

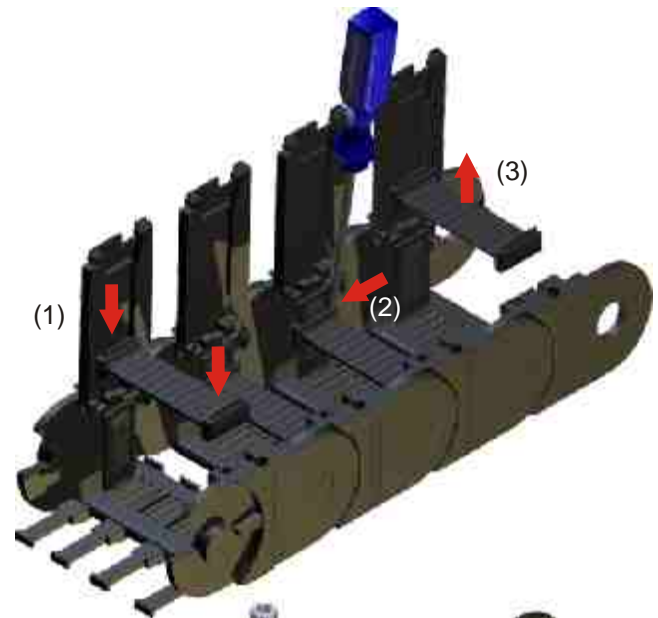

Mounting the energy chain and strain relief

Before mounting the energy chain horn stays may be assembled which can be used to fix the lines via cable ties. For most applications variable strain relief is recommended, to mount the anchor profile with the energy chain using the integrated connector. (1), (2).

It is also possible to attach the anchor profile as a separate strain relief. The anchor profile is suitable for various strain relief components (see design guidelines).

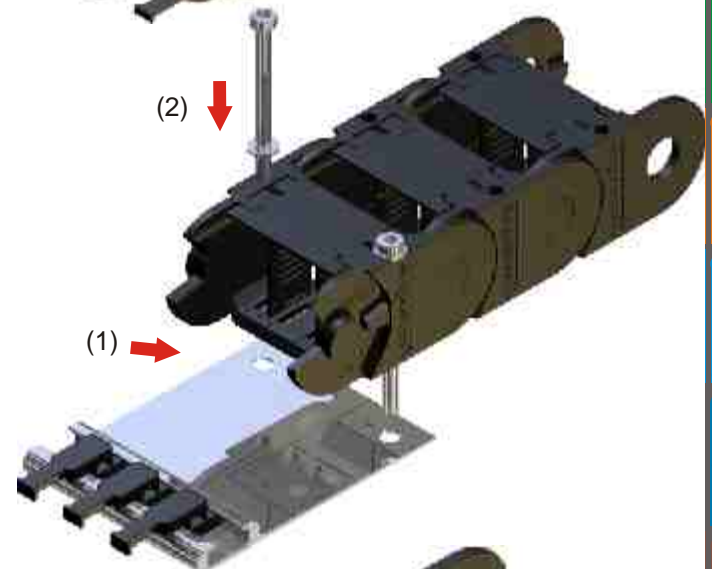

Snap assembly

The energy chain may be assembled with only one click using the Snap connector. Horn stays will be clipped at the stays as strain relief elements. After that the energy chain can be clicked in the designated position.

Alternatively, it is possible to mount the cable chains with flush mountig flange type brackets (1).

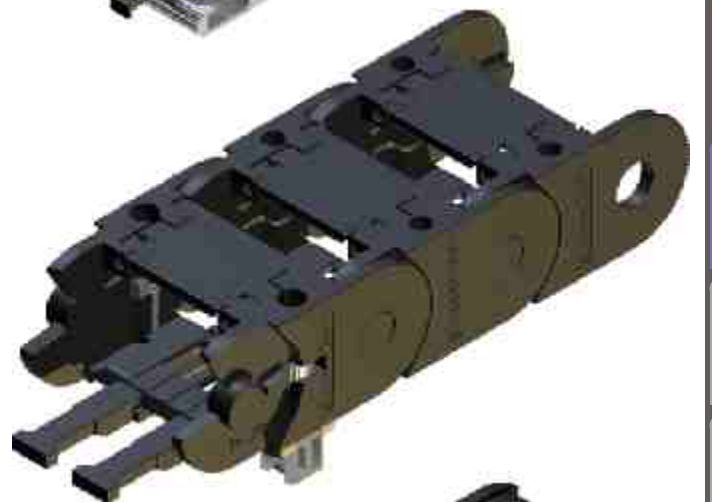

Maintenance of the energy chain

Kolibri energy chains are maintenance free. Like every mechanical system there will - depending on the ambient conditions - wear which must be observed. In case of this the energy chainspace has to be exchanged.

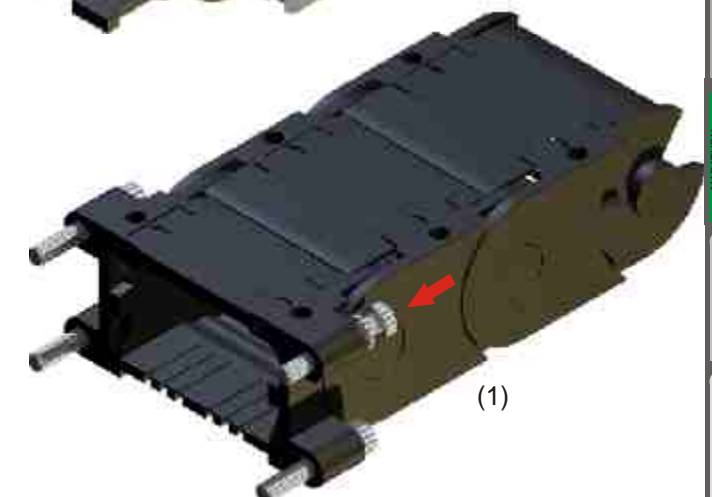

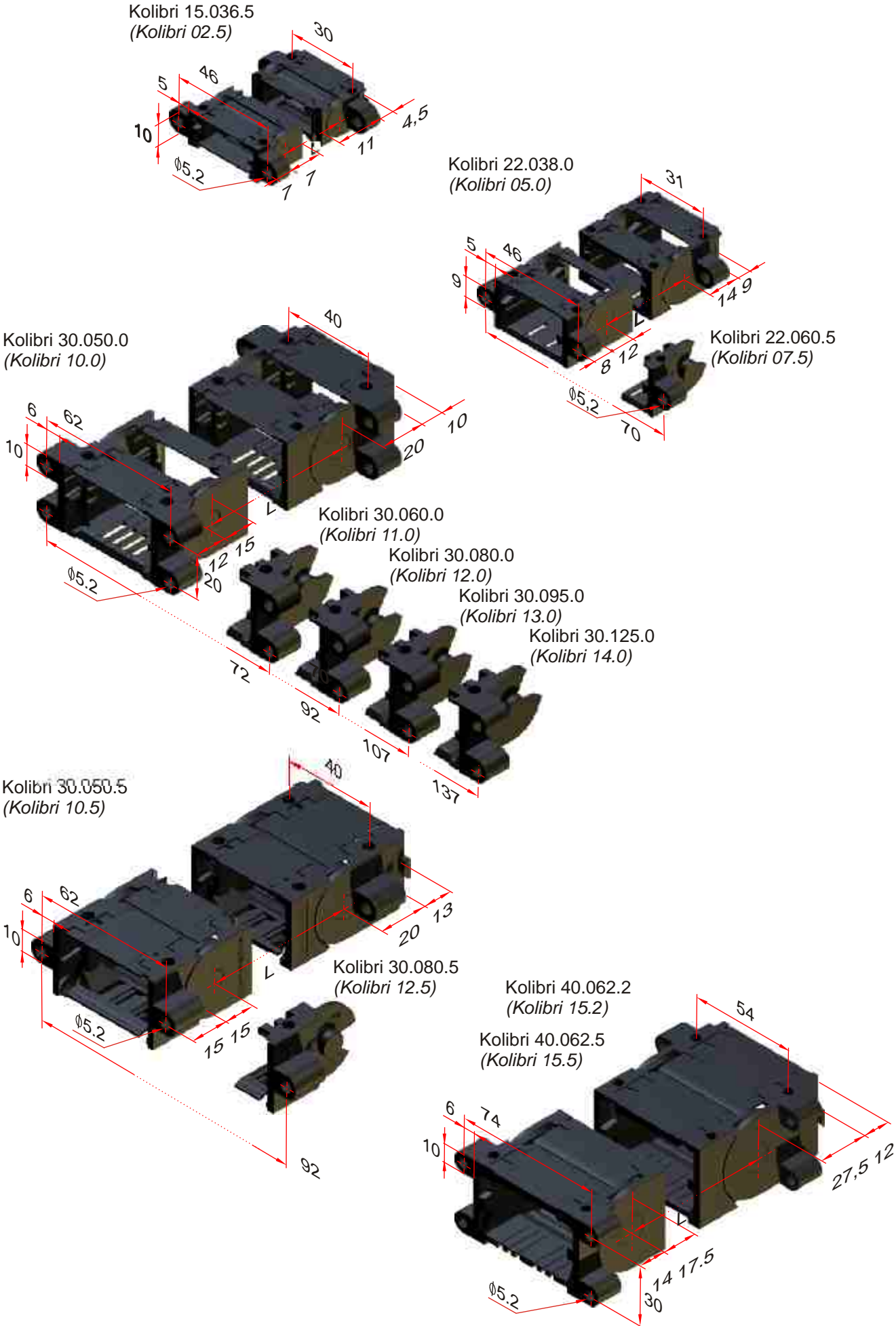

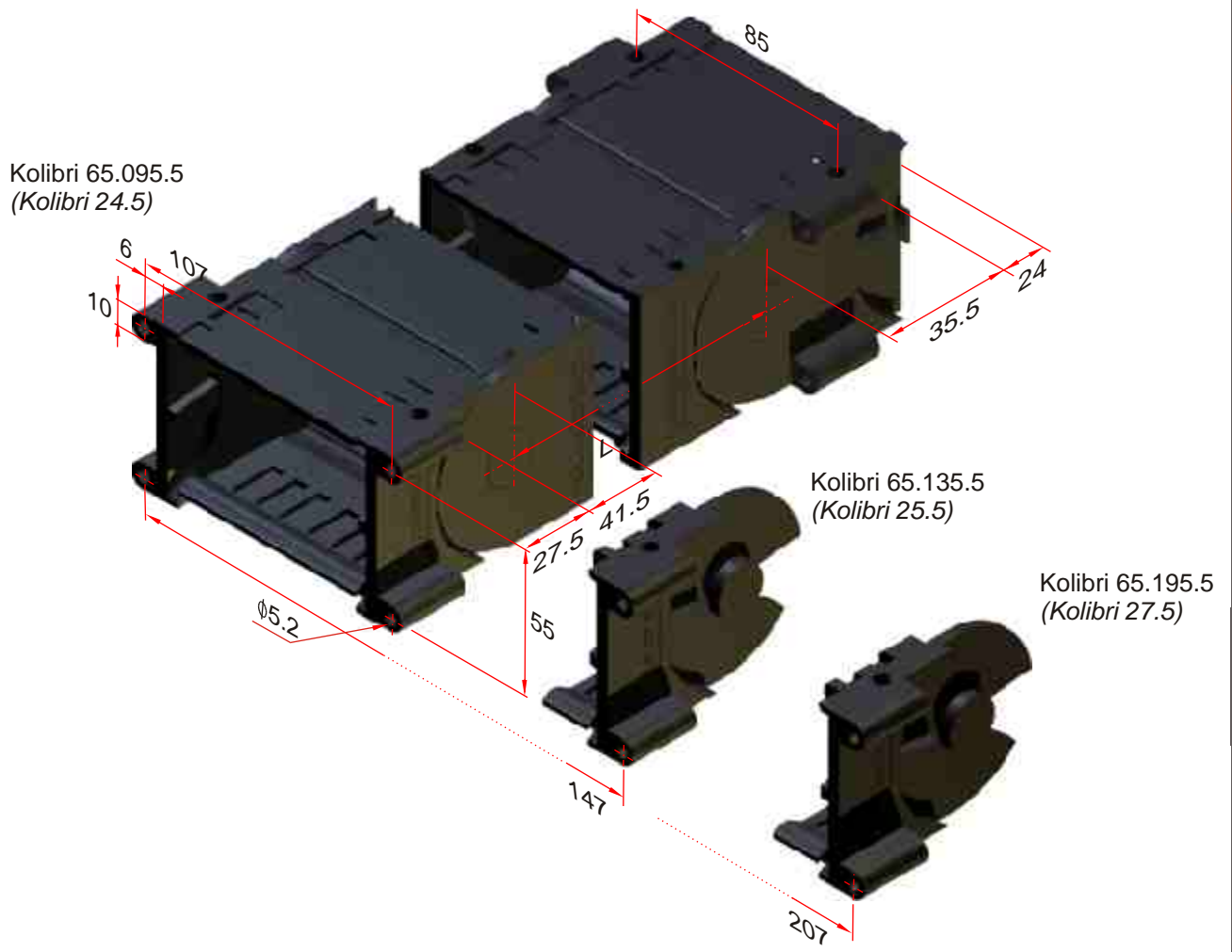
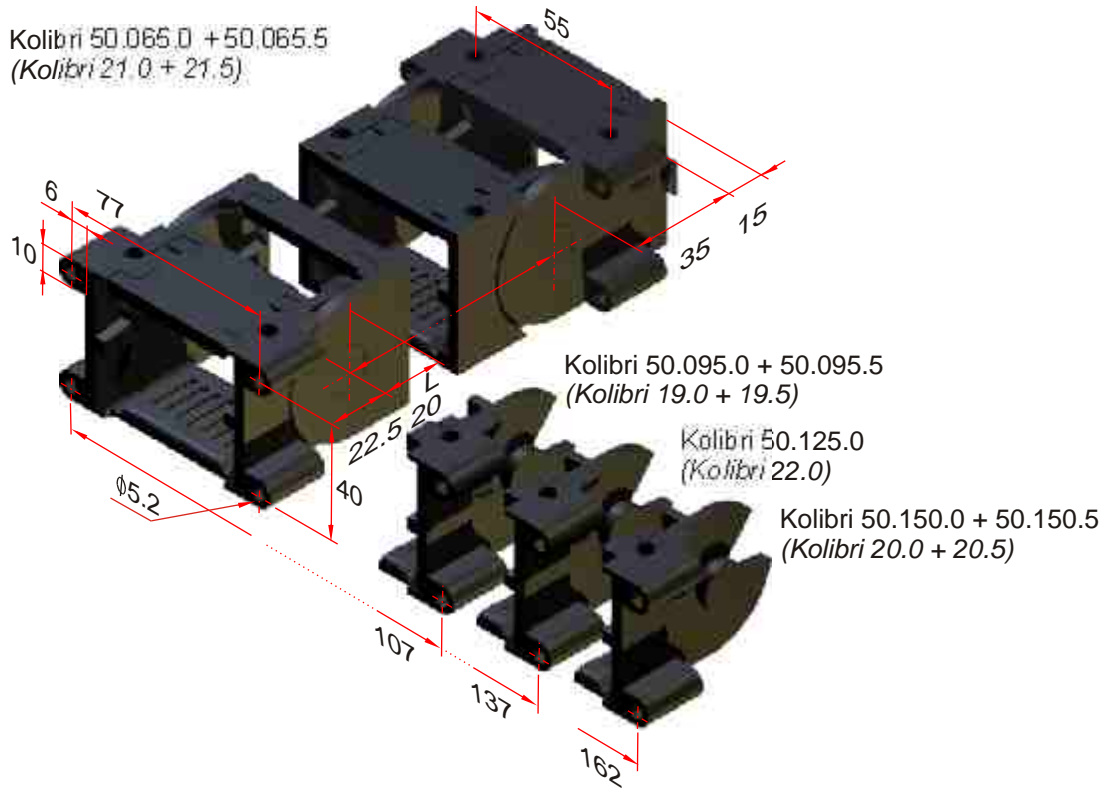

Kolibri parts 39



Kolibri	00.000.0		00.000.1		00.000.2 / .6		00.000.3		00.000.4		00.000.5		00.000.7						
	Radius	15	17.5	20	30	35	40	50	60	70	75	100	125	150	175	200	250	300	400
10.012.4 (00.3)	1089	-	-	1090	-	-	-	1091	-	-	-	-	-	-	-	-	-	-	-
13.023.4 short	-	-	-	-	2164	-	-	-	-	-	-	-	-	-	-	-	-	-	-
13.023.4 long	2137	-	-	-	2138	-	-	2139 (R55)	2140 (R80)	2141	-	-	-	-	-	-	-	-	-
15.015.3 (0)	-	1056	0435	0029	-	-	-	-	-	-	-	-	-	-	-	-	-	-	-
15.015.4 (0.3)	-	-	1116	1060	-	-	-	-	-	-	-	-	-	-	-	-	-	-	-
15.036.5 (02.5)	-	-	-	1156	-	-	1157	-	-	-	-	-	-	-	-	-	-	-	-
15.037.3 (02)	-	-	2191 ¹⁾	1983	-	-	-	-	-	-	-	-	-	-	-	-	-	-	-
15.051.0 (03)	-	-	0844	0845	-	-	-	-	-	-	-	-	-	-	-	-	-	-	-
22.025.4 (04.3)	-	-	-	-	0981	-	-	-	0982	-	0983	-	-	-	-	-	-	-	-
22.038.0 (05.0)	-	-	-	-	1686	-	1685	2133	1684	-	1683	-	-	-	-	-	-	-	-
22.038.1	-	-	-	-	1876	-	-	-	-	-	-	-	-	-	-	-	-	-	-
22.048.0 (06)	-	-	-	-	0840	-	-	-	0841	-	-	-	-	-	-	-	-	-	-
22.060.5 (07.5)	-	-	-	-	-	-	1259	-	1260	-	1261	-	-	-	-	-	-	-	-
30.030.3 (1)	-	-	-	-	-	0457	-	-	-	0004	-	-	-	0005	-	-	-	-	-
30.060.3 (2)	-	-	-	-	-	0006	-	-	-	0007	-	0615	-	0008	-	-	-	-	-
30.050.0 (10.0)	-	-	-	-	-	1224	-	1430	-	1225	1222	-	1226	-	1223	-	-	-	-
30.050.1 (10.1)	-	-	-	-	-	-	-	-	-	1835	1748	-	-	-	-	-	-	-	-
30.050.5 (10.5)	-	-	-	-	-	-	-	1002	-	1010	1003	-	1011	-	1004	-	-	-	-
30.060.0 (11.0)	-	-	-	-	-	1229	1377	-	-	1230	1227	-	1231	-	1228	-	-	-	-
30.060.1 (11.1)	-	-	-	-	-	-	-	-	-	1944	1750	-	-	-	-	-	-	-	-
30.080.0 (12.0)	-	-	-	-	-	1235	-	-	-	1236	1232	-	1233	-	1234	-	-	-	-
30.080.1 (12.2)	-	-	-	-	-	-	-	-	-	1394	1621	-	-	-	-	-	-	-	-
30.080.2	-	-	-	-	-	-	-	-	-	-	-	-	-	-	-	-	-	-	-
30.080.4	-	-	-	-	-	-	-	-	-	-	-	-	-	-	-	-	-	-	-
30.080.5 (12.5)	-	-	-	-	-	-	-	1798	-	-	1795	-	1796	-	1797	-	-	-	-
30.095.0 (13.0)	-	-	-	-	-	1239	-	-	-	1240	1237	1324	1241	-	1238	-	-	-	-
30.095.1 (13.1)	-	-	-	-	-	1992	-	-	-	1411	1645	1993	1994	-	1995	-	-	-	-
30.125.0 (14.0)	-	-	-	-	-	1245	-	-	-	1246	1242	-	1243	-	1244	-	-	-	-
30.125.1 (14.0)	-	-	-	-	-	1973	-	-	-	1974	1975	-	-	-	-	-	-	-	-
40.062.2 (15.0)	-	-	-	-	-	-	-	1489	-	1490	1491	-	1492	-	1493	-	-	-	-
40.062.5 (15.5)	-	-	-	-	-	-	-	-	-	1152	1163	-	1154	-	1155	-	-	-	-
40.075.2 (16.0)	-	-	-	-	-	-	-	1484	-	1485	1486	-	1487	-	1488	-	-	-	-
40.075.6	-	-	-	-	-	-	-	2056	-	2055	2054	-	2053	-	2052	-	-	-	-
40.112.7	-	-	-	-	-	-	-	2030/2031 (R55)		-	-	-	-	-	-	-	-	-	-
50.065.0 (21.0)	-	-	-	-	-	-	-	-	-	0971	0972	1256	0973	-	0974	0975	-	-	-
50.065.5 (21.5)	-	-	-	-	-	-	-	-	-	-	1005	-	1006	-	1007	1008	-	-	-
50.095.0 (19.0)	-	-	-	-	-	-	-	-	-	1138	1148	1431	1139	1325	1140	1141	-	-	-
50.095.1 (19.1)	-	-	-	-	-	-	-	-	-	1947	1948	1949	1950	1951	1952	2016	-	-	-
50.095.2 (19.2)	-	-	-	-	-	-	-	-	-	1619	1644	1483	1370	-	-	-	-	-	-
50.095.5 (19.5)	-	-	-	-	-	-	-	-	-	-	1012	-	1013	-	1014	1016	-	-	-
50.125.0 (22.0)	-	-	-	-	-	-	-	-	-	1292	1288	2158	1289	-	1290	1291	-	-	-
50.150.0 (20.0)	-	-	-	-	-	-	-	-	-	1287	1283	-	1284	-	1285	1286	-	-	-
50.150.1 (20.1)	-	-	-	-	-	-	-	-	-	1516	2447	-	2051	-	2109	2112	-	-	-
50.150.5 (20.5)	-	-	-	-	-	-	-	-	-	-	1061	-	1062	-	1063	1064	-	-	-
65.095.1 (24.1)	-	-	-	-	-	-	-	-	-	-	-	1252	1253	-	1254	-	1255	-	-
65.095.5 (24.5)	-	-	-	-	-	-	-	-	-	-	-	1084	1085	-	1086	-	1087	-	-
65.135.1 (25.1)	-	-	-	-	-	-	-	-	-	-	-	1753	1754	-	1755	-	1756	1757	-
65.135.5 (25.5)	-	-	-	-	-	-	-	-	-	-	-	1076	1077	-	1078	-	1079	1752	-
65.195.1 (27.1)	-	-	-	-	-	-	-	-	-	-	-	1758	1922	-	1759	-	1760	-	-
65.195.5 (27.5)	-	-	-	-	-	-	-	-	-	-	-	1080	1081	-	1082	-	1083	-	-

¹⁾ R24
44

Kolibri PART NUMBERS

special material parts like UI94 V-0, EX or other have to be named in the order



Kolibri

Kolibri	11	12	stay thickness	2 mm	3 mm	2 mm	2 mm	4 mm	2 mm	3 mm	4 mm	4 mm
10.012.4	-	-	-	-	-	-	-	-	-	-	-	-
13.023.4	-	-	-	-	-	-	-	-	-	-	-	-
13.023.4	-	-	-	-	-	-	-	-	-	-	-	-
15.015.3	-	-	-	-	-	-	-	-	-	-	-	-
15.015.4	-	-	-	-	-	-	-	-	-	-	-	-
15.036.5	-	1708	-	-	-	-	-	-	-	-	-	-
15.037.3	-	-	-	-	-	-	-	-	-	-	-	-
15.051.0	1707	-	-	-	-	-	-	-	-	-	-	-
22.025.4	-	-	-	-	-	-	-	-	-	-	-	-
22.038.0	1687	-	1688	-	-	-	-	-	-	-	-	-
22.038.1	1687	-	1688	-	-	-	-	-	-	-	-	-
22.048.0	1707	-	-	-	-	-	-	-	-	-	-	-
22.060.5	-	1709	1294	-	-	-	-	-	-	-	-	-
30.030.3	-	-	-	-	-	-	-	-	-	-	-	-
30.060.3	-	-	-	-	-	-	-	-	-	-	-	-
30.050.0	1698	-	-	1258	-	-	-	-	-	-	-	-
30.050.1	1698	-	-	1258	-	-	-	-	-	-	-	-
30.050.5	-	1710	-	-	1017	-	-	-	-	-	-	-
30.060.0	1697	-	-	1258	-	-	-	-	-	-	-	-
30.060.1	1697	-	-	1258	-	-	-	-	-	-	-	-
30.080.0	1695	-	-	1258	-	-	-	-	-	-	-	-
30.080.1	1695	-	-	1258	-	-	-	-	-	-	-	-
30.080.2	1695	-	-	-	-	-	-	-	-	-	-	-
30.080.4	-	-	-	-	-	-	-	-	-	-	-	-
30.080.5	-	-	-	-	1017	-	-	-	-	-	-	-
30.095.0	1696	-	-	1258	-	-	-	-	-	-	-	-
30.095.1	1696	-	-	1258	-	-	-	-	-	-	-	-
30.125.0	1706	-	-	1258	-	-	-	-	-	-	-	-
30.125.1	1706	-	-	1258	-	-	-	-	-	-	-	-
40.062.2	1694	-	-	-	-	-	1521	-	-	-	-	-
40.062.5	-	1577	-	-	-	1268	-	-	-	-	-	-
40.075.2	1693	-	-	-	-	-	1521	-	-	-	-	-
40.075.6	1693	-	-	-	-	-	1521	-	-	-	-	-
40.112.7	(PKK 120)	-	-	-	-	-	2035	-	-	-	-	-
50.065.0	1692	-	-	-	-	-	-	1113	-	-	-	-
50.065.5	-	1711	-	-	-	-	-	1113	-	-	-	-
50.095.0	1691	-	-	-	-	-	-	1113	-	-	-	-
50.095.1	1691	-	-	-	-	-	-	1113	-	-	-	-
50.095.2	1691	-	-	-	-	-	-	-	-	1451	-	-
50.095.5	-	1655	-	-	-	-	-	1113	-	-	-	-
50.125.0	1320	-	-	-	-	-	-	-	1326	-	-	-
50.150.0	1318	-	-	-	-	-	-	-	1326	-	-	-
50.150.1	1318	-	-	-	-	-	-	-	1326	-	-	-
50.150.5	-	1624	-	-	-	-	-	1113	-	-	-	-
65.095.1	1470	-	-	-	-	-	-	-	-	-	-	1129
65.095.5	-	1625	-	-	-	-	-	-	-	-	-	1129
65.135.1	1354	-	-	-	-	-	-	-	-	-	-	1129
65.135.5	-	1626	-	-	-	-	-	-	-	-	-	1129
65.195.1	1355	-	-	-	-	-	-	-	-	-	-	1129
65.195.5	-	1627	-	-	-	-	-	-	-	-	-	1129

Kolibri parts 39

Kolibri parts 39



8



14



13



17



16



15



3

4



20



21

Kolibri	FK	notched hor. divider	ladderstay	PTF	PT-55	PT-75	head side flange	1576	1814
13.023.4	-	flying	-	-	flying	55-80	75-100	-	-
13.023.4	-	-	-	-	-	-	-	-	-
15.015.3	-	-	-	-	-	-	-	-	-
15.015.4	-	-	-	-	-	-	-	-	-
15.036.5	-	-	-	-	-	-	1339	-	-
15.037.3	-	-	-	-	-	-	-	-	-
15.051.0	-	-	-	-	-	-	-	-	-
22.025.4	-	-	-	-	-	-	-	-	-
22.038.0	-	-	-	-	-	-	1745	-	-
22.038.1	-	-	-	-	-	-	-	-	-
22.048.0	-	-	-	-	-	-	-	-	-
22.060.5	-	1127	-	-	-	-	1340	-	-
30.030.3	-	-	-	-	-	-	-	-	-
30.060.3	-	-	-	-	-	-	-	-	-
30.050.0	1363	-	-	-	-	-	1329	-	-
30.050.1	1363	-	-	-	-	-	1329	-	-
30.050.5	1363	1127	-	-	-	-	1341	-	-
30.060.0	1363	-	-	-	-	-	1330	-	-
30.060.1	1363	-	-	-	-	-	1330	-	-
30.080.0	1363	-	-	-	-	-	1331	-	-
30.080.1	1363	-	-	-	-	-	1331	-	-
30.080.2	1363	-	-	1665	1927	-	-	-	-
30.080.4	1363	-	-	-	-	-	1331	-	-
30.080.5	1363	1127	-	-	-	-	-	-	-
30.095.0	1363	-	-	-	-	-	1332	-	-
30.095.1	1363	-	-	-	-	-	1332	-	-
30.125.0	1363	-	-	-	-	-	1333	-	-
30.125.1	1363	-	-	-	-	-	1333	-	-
40.062.2	1363	-	-	1665	1927	-	1996 / 1997	-	-
40.062.5	1363	-	-	-	-	-	1343	-	-
40.075.2	1363	-	-	1665	1927	-	-	-	-
40.075.6	1363	-	-	1665	1927	-	-	-	-
40.112.7	-	-	-	-	-	-	2037 / 2036	-	2038
50.065.0	1269	1127	-	-	-	-	1336		-
50.065.5	1269	1127	-	-	-	-	1346	-	-
50.095.0	1269	1127	1127	-	-	-	1334	-	-
50.095.1	1269	1127	1127	-	-	-	1334	-	-
50.095.2	1269	-	-	1665	1927	-	-	-	-
50.095.5	1269	1127	1127	-	-	-	1344	-	-
50.125.0	1269	-	-	-	-	-	1337	-	-
50.150.0	1269	-	-	-	-	-	1335	-	-
50.150.1	1269	-	-	-	-	-	1335	-	-
50.150.5	1269	1127	1127	-	-	-	1345	-	-
65.095.1	1269	-	-	1665	1927	-	1347	-	-
65.095.5	1269	-	-	1665	1927	-	1347	-	-
65.135.1	1269	-	-	1665	1927	0879	0880	-	-
65.135.5	1269	-	-	1665	1927	0879	0880	-	-
65.195.1	1269	-	-	1665	1927	0879	0880	-	-
65.195.5	1269	-	-	1665	1927	0879	0880	-	-

Kolibri PART NUMBERS



special material parts like UI94 V-0, EX or other have to be named in the order

<i>Kolibri</i>	anchor profile	ZL50	blue ribbon	ZLA 8 (PZ SLP220)	ZHS10	ZLS10	HS55	HS65	HS75	HS85
13.023.4	-	-	-	-	-	-	-	-	-	-
13.023.4	-	-	-	-	-	-	-	-	-	-
15.015.3	-	-	-	-	-	-	-	-	-	-
15.015.4	-	-	-	-	-	-	-	-	-	-
15.036.5	-	-	-	-	-	-	-	-	-	-
15.037.3	-	-	-	-	-	-	-	-	-	-
15.051.0	-	-	-	-	-	-	-	-	-	-
22.025.4	1163	-	1142	1159	0778	1407	1160	-	-	-
22.038.0	1163	-	1142	1159	0778	1407	1160	-	-	-
22.038.1	1163	-	1142	1159	0778	1407	1160	-	-	-
22.048.0	1163	-	1142	1159	0778	1407	1160	-	-	-
22.060.5	1163	-	1142	1159	0778	1407	1160	-	-	-
30.030.3	1163	-	1142	1159	0778	1407	1160	-	-	-
30.060.3	1163	-	1142	1159	0778	1407	1160	-	-	-
30.050.0	1163	-	1142	1159	0778	1407	1160	1802	-	-
30.050.1	1163	-	1142	1159	0778	1407	1160	1802	-	-
30.050.5	1163	-	1142	1159	0778	1407	1160	-	-	-
30.060.0	1163	-	1142	1159	0778	1407	1160	1802	-	-
30.060.1	1163	-	1142	1159	0778	1407	1160	1802	-	-
30.080.0	1163	-	1142	1159	0778	1407	1160	1802	1503 ¹⁾	-
30.080.1	1163	-	1142	1159	0778	1407	1160	1802	1503 ¹⁾	-
30.080.2	1163	-	1142	1159	0778	1407	1160	-	1503	-
30.080.4	1163	-	1142	1159	0778	1407	1160	-	1503	-
30.080.5	1163	-	1142	1159	0778	1407	1160	-	-	-
30.095.0	1163	-	1142	1159	0778	1407	1160	1802	-	-
30.095.1	1163	-	1142	1159	0778	1407	1160	1802	-	-
30.125.0	1163	-	1142	1159	0778	1407	1160	1802	-	-
30.125.1	1163	-	1142	1159	0778	1407	1160	1802	-	-
40.062.2	1163	-	1142	1159	0778	1407	1160	-	1503	-
40.062.5	1163	-	1142	1159	0778	1407	1160	-	-	-
40.075.2	1163	-	1142	1159	0778	1407	1160	-	1503	-
40.075.6	1163	-	1142	1159	0778	1407	1160	-	1503	-
40.112.7	1163	-	-	1159	0778	1407	1160	-	-	-
50.065.0	1163	1273	1142	1159	-	1407	1160	-	-	1504
50.065.5	1163	1273	1142	1159	-	1407	1160	-	-	-
50.095.0	1163	1273	1142	1159	-	1407	1160	-	1503 ¹⁾	1504
50.095.1	1163	1273	1142	1159	-	1407	1160	-	1503 ¹⁾	1504
50.095.2	1163	1273	1142	1159	-	1407	1160	-	1503	-
50.095.5	1163	1273	1142	1159	-	1407	1160	-	-	-
50.125.0	1163	1273	1142	1159	-	1407	1160	-	-	1504
50.150.0	1163	1273	1142	1159	-	1407	1160	-	-	1504
50.150.1	1163	1273	1142	1159	-	1407	1160	-	-	1504
50.150.5	1163	1273	1142	1159	-	1407	1160	-	-	-
65.095.1	1163	1273	1142	1159	-	1407	1160	-	-	-
65.095.5	1163	1273	1142	1159	-	1407	1160	-	-	-
65.135.1	1163	1273	1142	1159	-	1407	1160	-	-	-
65.135.5	1163	1273	1142	1159	-	1407	1160	-	-	-
65.195.1	1163	1273	1142	1159	-	1407	1160	-	-	-
65.195.5	1163	1273	1142	1159	-	1407	1160	-	-	-

1) with horn stay connectors